

# Survey on the physics potentials at high intensity GeV proton accelerator

Chen WU, NJU/IHEP/OU

2017/10/06 高精度前沿物理研讨会



# Outline

- Proton Sources in The World
- Physics with Proton Sources

# Outline

- Proton Sources in The World
- Physics with Proton Sources

# Proton Sources in The World

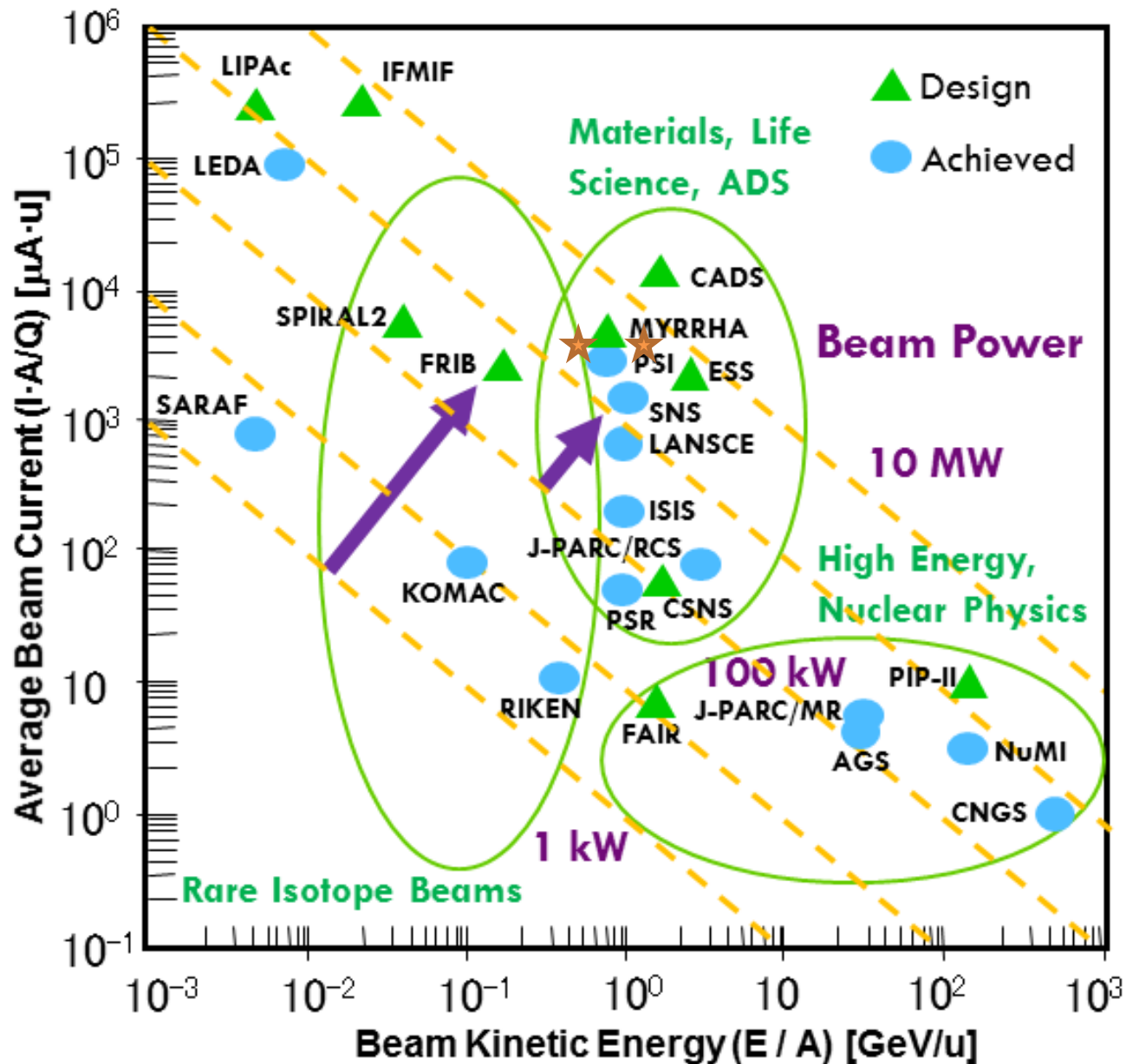

# Proton Sources in The World

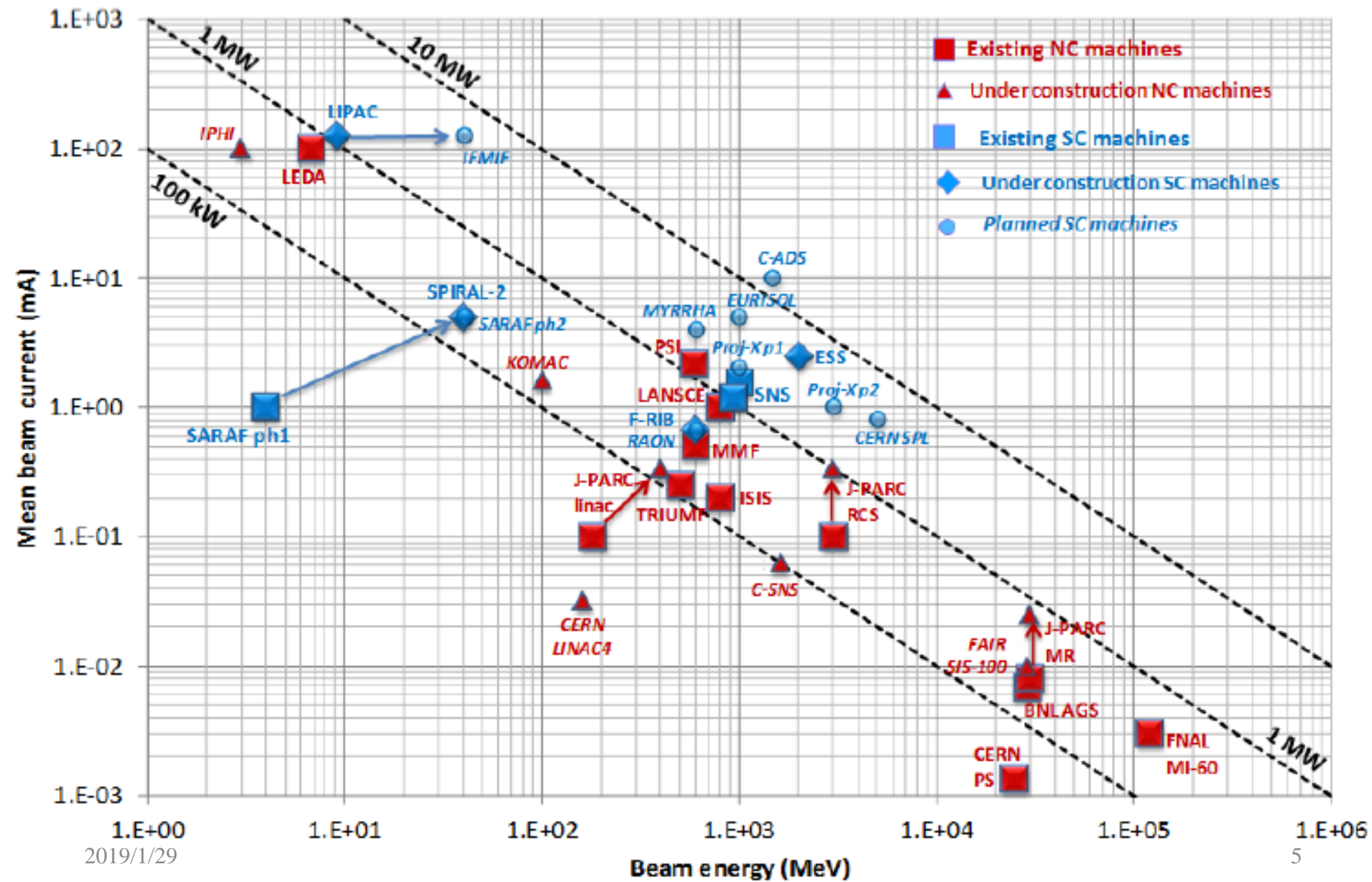

# Proton Sources in The World

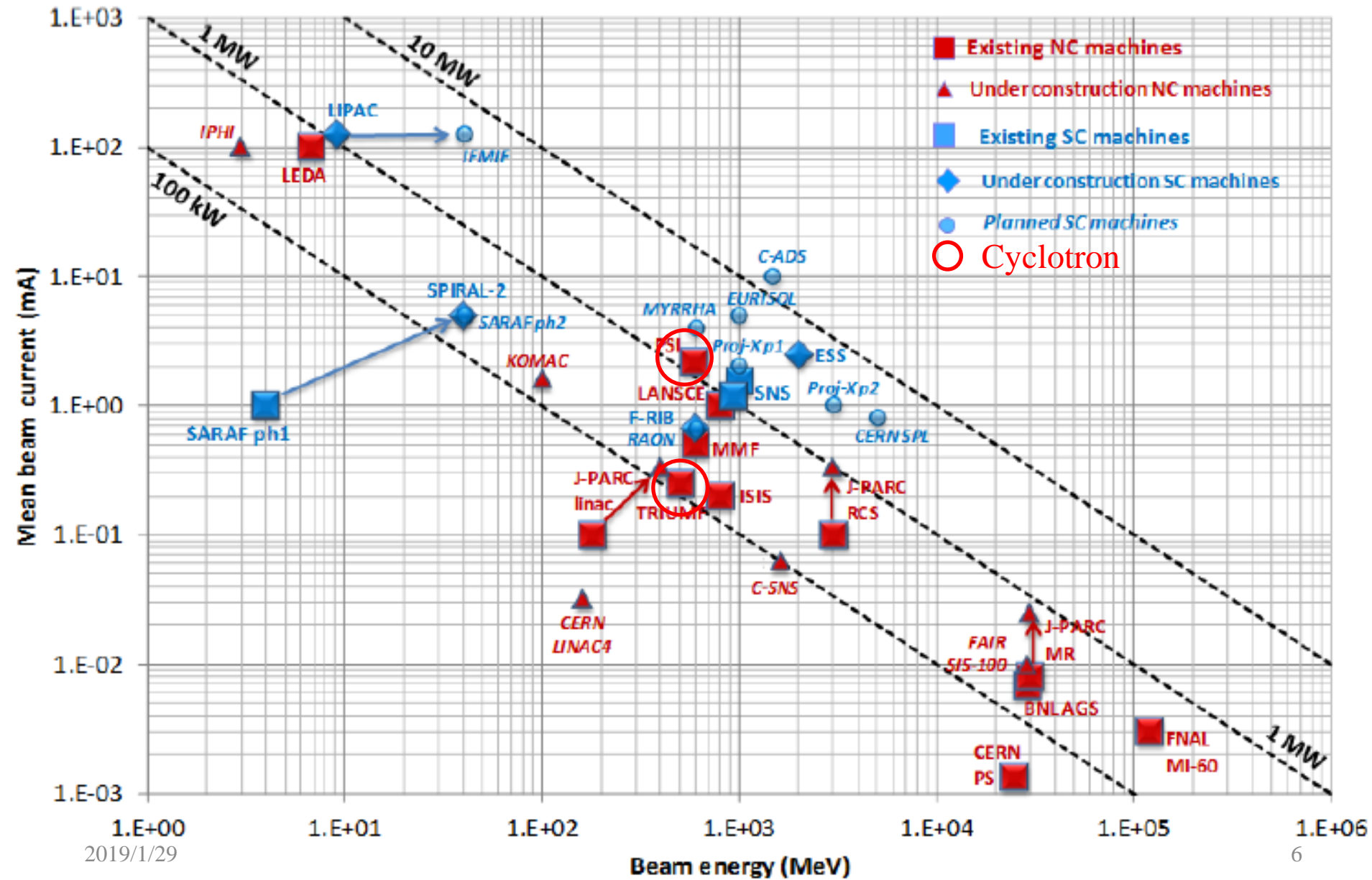

# Proton Sources in The World

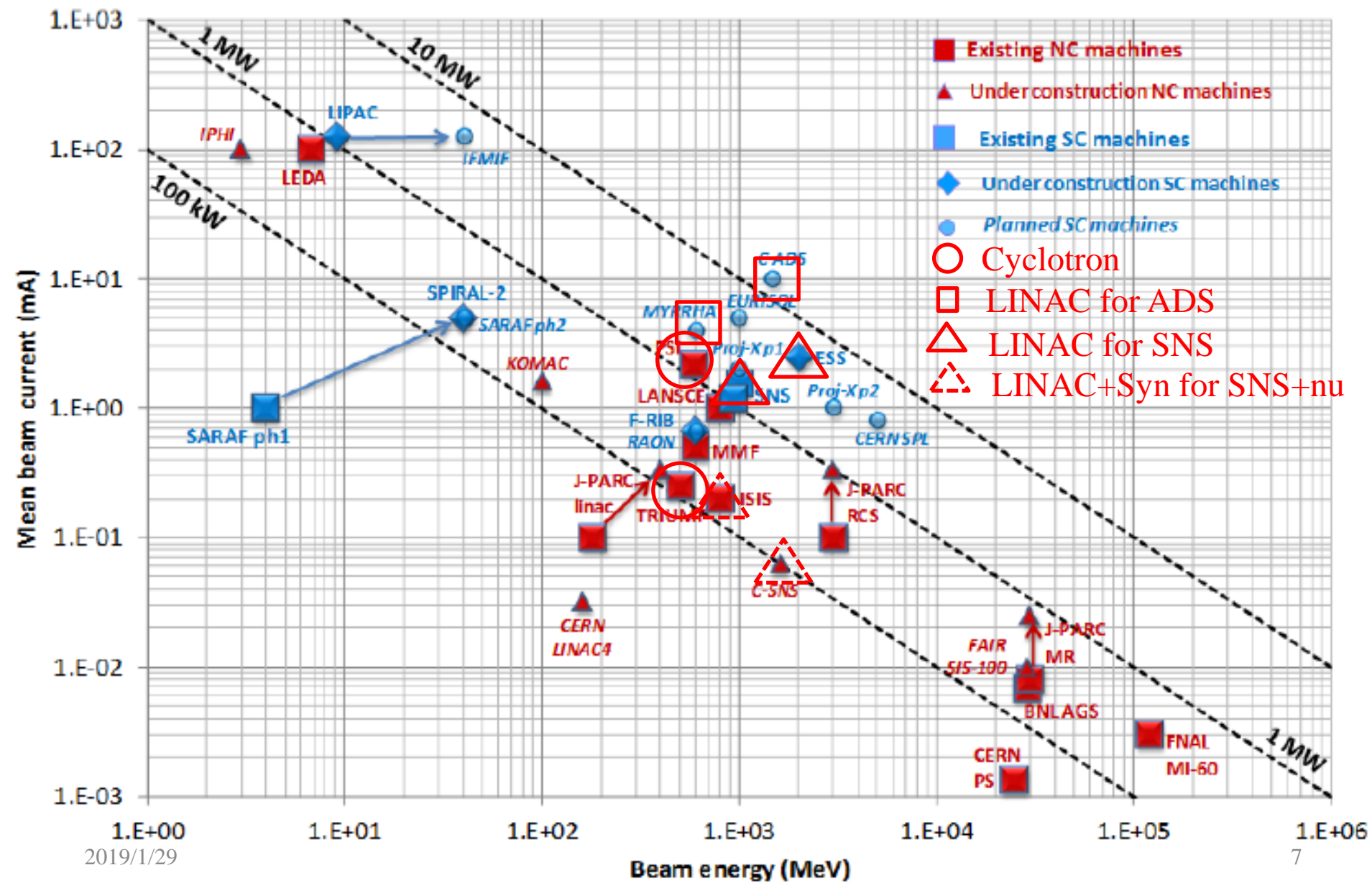

# Proton Sources in The World

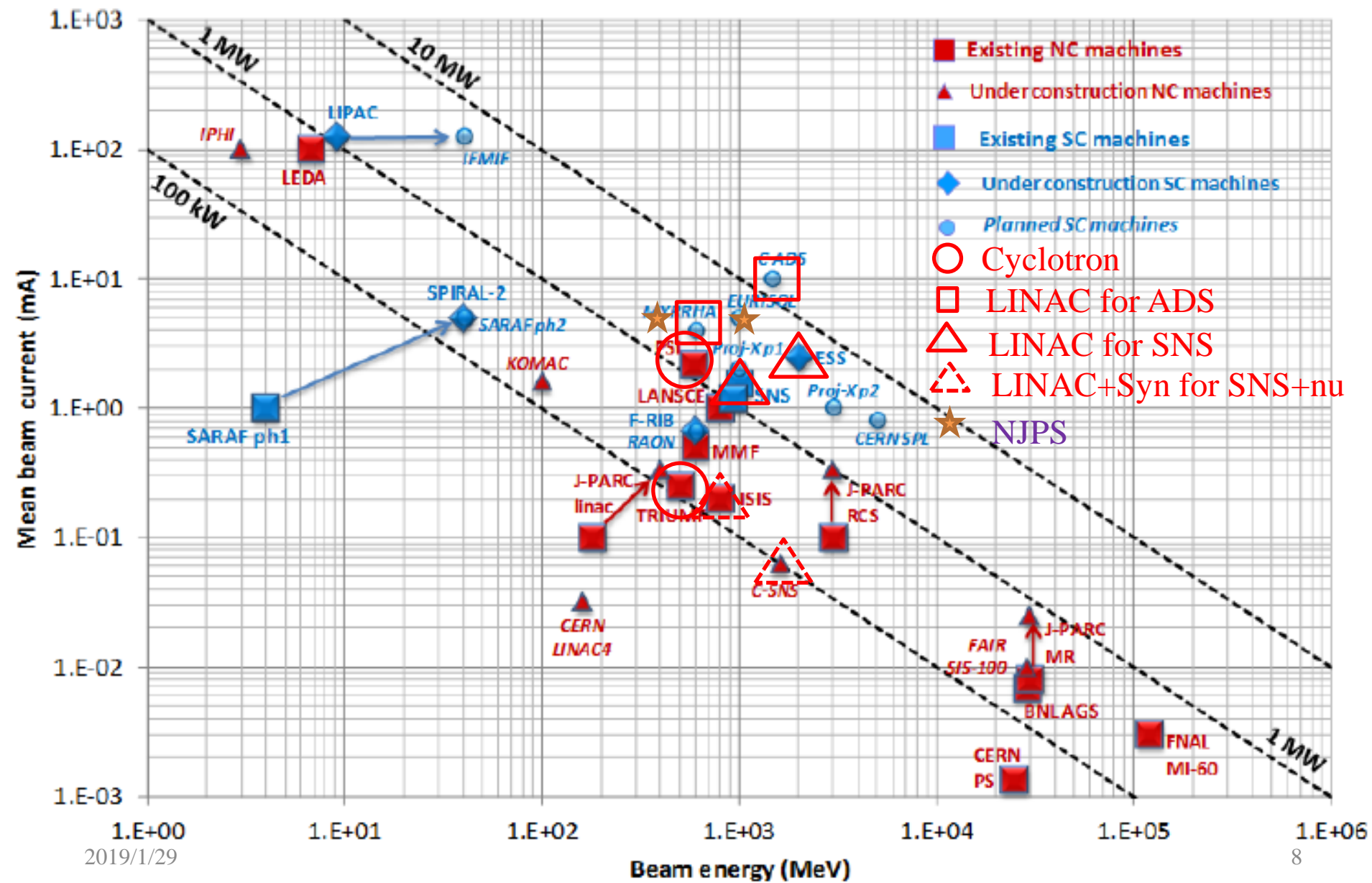

# Proton Sources in The World

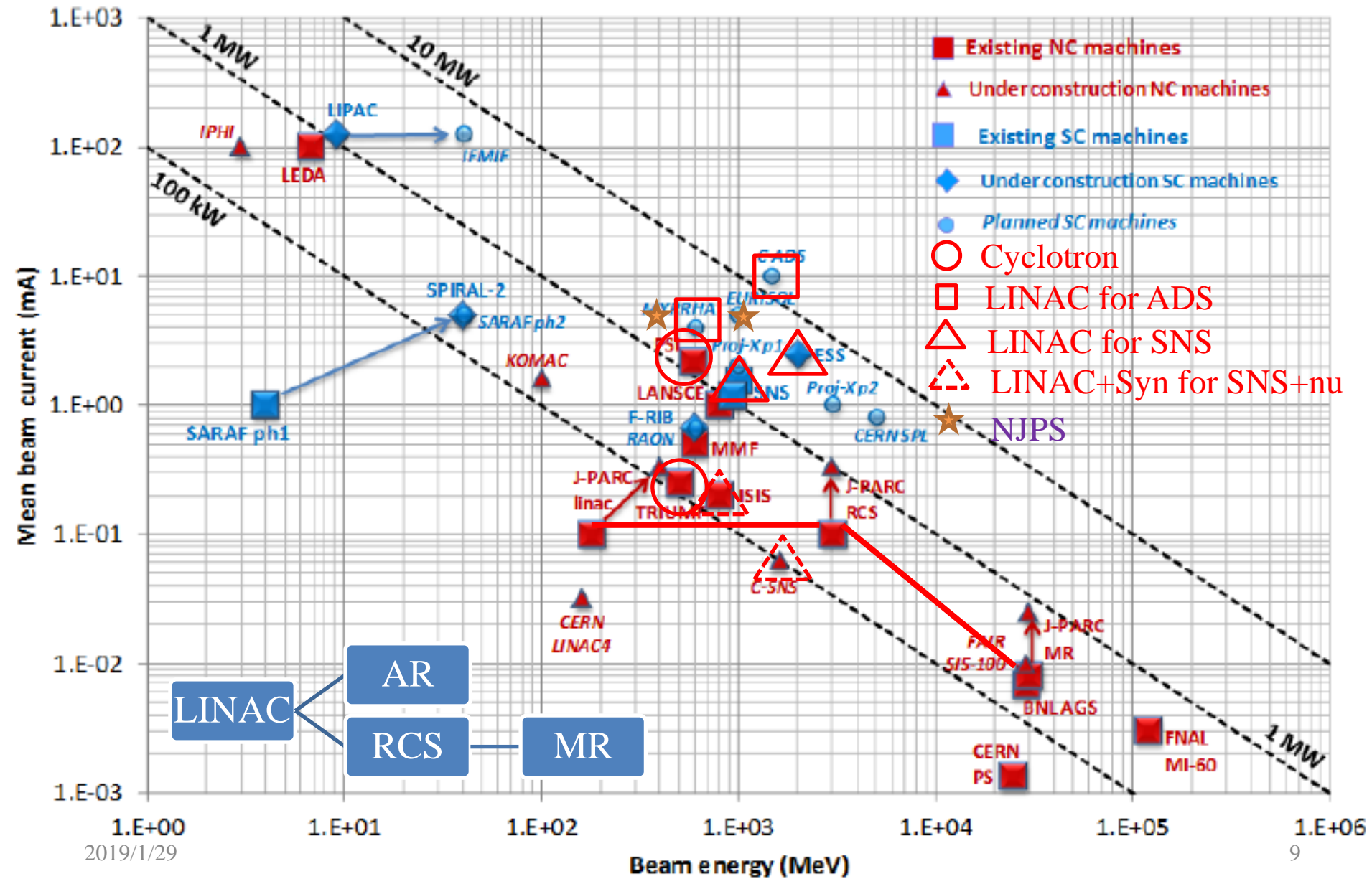

# Proton Sources in The World HE

Acc Name	DF	Beam Power	Beam Energy	Reliability	ppp 10 <sup>12</sup>	Comment
FANL-LINAC			400MeV			FermiLab, LINAC
FANL-MI		700kW	8GeV	83%		FermiLab, LINAC+Booster+MR
PIP-II-LINAC	1%	16kW	800MeV			FermiLab, LINAC SC
PIP-II-MI		1.2~2.3 MW	120GeV			FermiLab, LINAC+Booster+MR
PIP-III-LINAC			2~8GeV			FermiLab, LINAC
PIP-III-MI		>2MW	120GeV			FermiLab, LINAC+Booster+MR
Project X LINAC	96%	2.87 MW	3 GeV		/	FermiLab, LINAC
Project X MI	0.01%~	2.4MW	120GeV		150	FermiLab, LINAC+Booster+MR
JPARC LINAC	1.25%	250kW	400MeV			JPARC, LINAC
JPARC RCS		500kW	3GeV	90%		JPARC, LINAC+RCS
JPARC MR	3%	470kW	30GeV			JPARC, LINAC+RCS+MR
JPARC+ LINAC						JPARC, LINAC
JPARC+ RCS		1.1MW	3GeV			JPARC, LINAC+RCS
JPARC+ MR		1.3MW	30GeV			JPARC, LINAC+RCS+MR

# Proton Sources in The World ME

Acc Name	DF	Beam Power	Beam Energy	Relia bility	ppp 10 <sup>12</sup>	Comment
PSI	100%	1.4MW	590MeV	87%	/	PSI, Cyclotron, muon/pion
TRIUMF	100%	200kW	500MeV		/	TRIUMF, Cyclotron, muon/pion
SNS	5%	1.4MW	1 GeV	86%	110	ORNL, LINAC+Accumulator,
SNS+	6%	3MW	1.3 GeV		250	ORNL, LINAC+Accumulator,
LANSCE	6.25%	800kW	800 MeV	87%		LANL, LINAC+Accumulator, halted at 1998, restore by 2017
CNGS		400kW	400 GeV	80%		CERN nu to Gran Sasso, LINAC+Syn, LBNE
AGS	0.3%	85 kW	24 GeV		9	BNL, LINAC+Booster+MR, g-2
AGS+	0.1%	1MW	28 GeV		4	BNL, LINAC+Booster+MR
ESS	4%	5MW	2.5 GeV	95%		European SS, LINAC, ESSnuSB
ISIS LINAC	1%	17.5 kW	70MeV		31	UK, LINAC
ISIS	1%	200 kW	800MeV		31	UK, LINAC+Syn, MICE, SNS



# Outline

- Proton Sources in The World
- **Physics with Proton Sources**

# Physics with Proton Sources

- Neutrino Physics
  - Neutrino Oscillation
  - Sterile Neutrino
  - Heavy Neutrino.
- Muon Physics
  - CLFV
  - $g-2$
  - $\mu$ EDM
  - Precision Measurements
- Kaon/Pion Physics
  - $K \rightarrow \pi, \nu, \nu$
- Neutron Physics
  - nEDM

# Physics with Proton Sources

- Neutrino Physics
  - Neutrino Oscillation
  - Sterile Neutrino
  - Heavy Neutrino.
- Muon Physics
  - CLFV
  - $g-2$
  - $\mu$ EDM
  - Precision Measurements
- Kaon/Pion Physics
  - $K \rightarrow \pi, \nu, \nu$
- Neutron Physics
  - nEDM

# Prospective Discovery

- From 2020 to 2030
  - **Discovery of Neutrino CP violation**
  - **Determination of Mass Hierarchy [MH]**
    - **If inverted MH, discovery of Majorana Neutrino mass with the neutrino-less double beta decay.**
  - **Determination of neutrino masses via cosmological observations.**
  - **Supernova Neutrinos**
  - **Dark Matter via neutrino astronomy**
  - **Sterile Neutrinos**
- **After 2030**, many precise measurements of
  - **Neutrino CP phase, Matter effect, Neutrino mass, the number of Sterile neutrinos, etc..**
  - **Proton Decay**

T. Nakaya @ NuFact16

# Anticipated Schedule

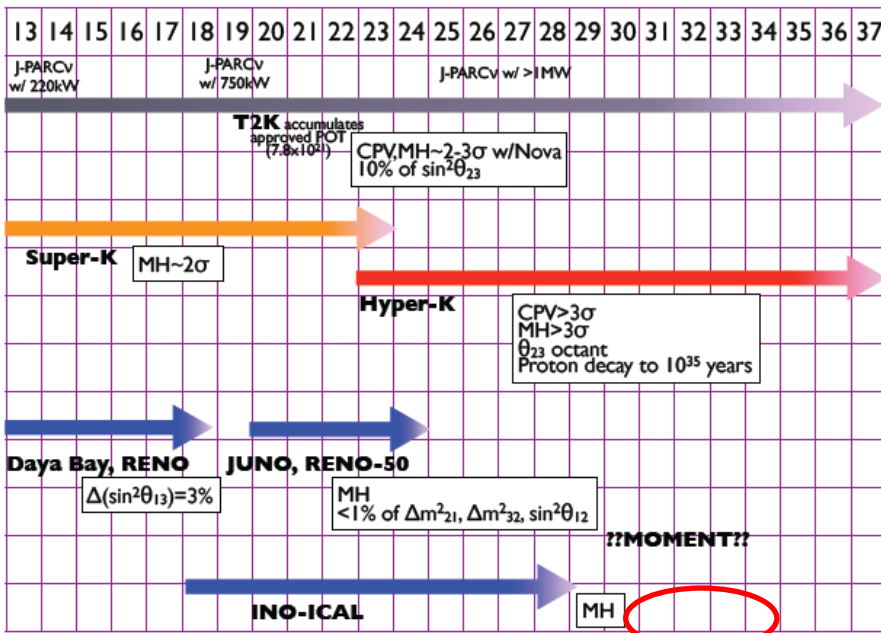

Ref.: Initial report from the ICFA Neutrino Panel  
arXiv:1405.7052

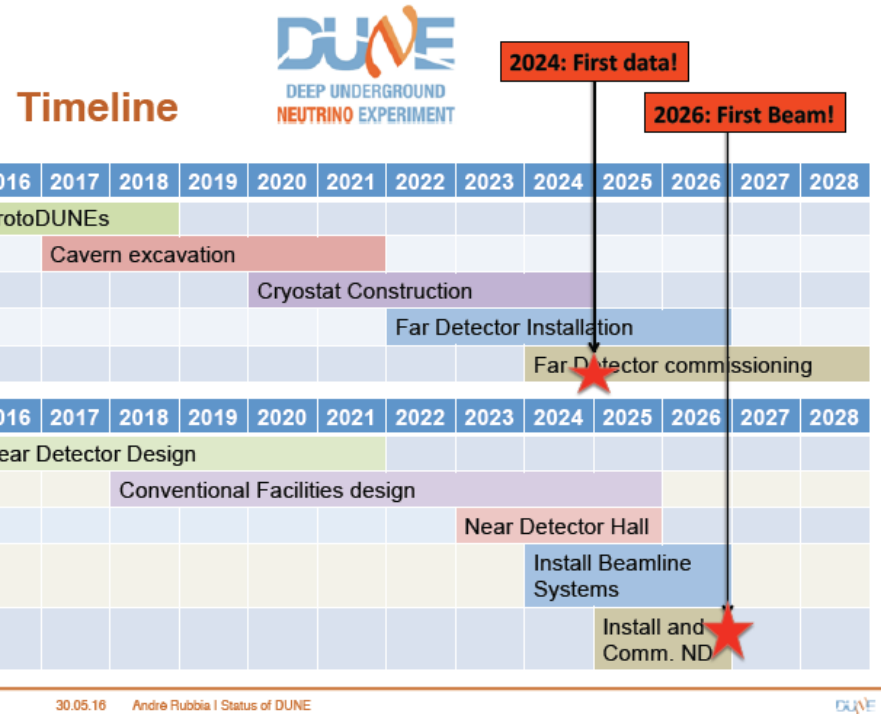

Ref.: A. Rubbia at the third International Meeting for Large Neutrino Infrastructures

T. Nakaya @ NuFact16

## CP Violation (50% Coverage)

Physics milestone	Exposure kt · MW · year (reference beam)	Exposure kt · MW · year (optimized beam)
1° $\theta_{23}$ resolution ( $\theta_{23} = 42^\circ$ )	70	45
CPV at $3\sigma$ ( $\delta_{CP} = +\pi/2$ )	70	60
CPV at $3\sigma$ ( $\delta_{CP} = -\pi/2$ )	160	100
CPV at $5\sigma$ ( $\delta_{CP} = +\pi/2$ )	280	210
MH at $5\sigma$ (worst point)	400	230
10° resolution ( $\delta_{CP} = 0$ )	450	290
CPV at $5\sigma$ ( $\delta_{CP} = -\pi/2$ )	525	320
CPV at $5\sigma$ 50% of $\delta_{CP}$	810	550
Reactor $\theta_{13}$ resolution ( $\sin^2 2\theta_{13} = 0.084 \pm 0.003$ )	1200	850
CPV at $3\sigma$ 75% of $\delta_{CP}$	1320	850

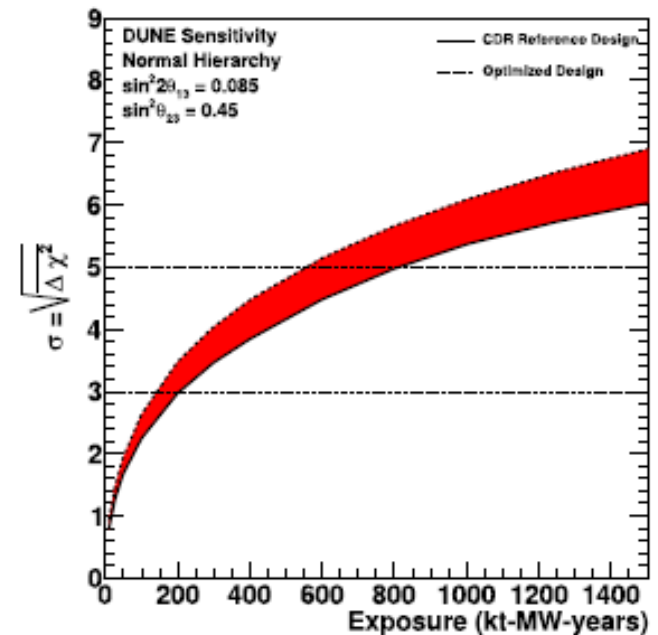

- ◆ Many milestones expected throughout experimental run:
  - 1%  $\theta_{23}$  resolution ( $\theta_{23} = 42^\circ$ ): **45** kt-MW-years
  - Definitive MH determination ( $\geq 5\sigma$  for all values of  $\delta_{CP}$ ): **230** kt-MW-years
  - CPV at  $5\sigma$  ( $\delta_{CP} = -\pi/2$ ): **320** kt-MW-years
  - Reactor  $\theta_{13}$  resolution: **850** kt-MW-years

# $\nu$ -beam facilities for LBL exp. in operation

- \* J-PARC  $\nu$  beam
- \* OA beam : Neutrino energy  $\sim 0.7$  GeV
- \* Flux at ND/SK is estimated based on HD production measurement by NA61/SHINE experiment with  $\sim 10\%$  uncertainty.
- \* 425kW beam operation achieved.  
→  $2.27 \times 10^{14}$  p/pulse
- \* 440kW trial is also performed.
- \* 2018 J-PARC MR PS upgrade  
: Cycle: 2.48s → 1.3s
- \*  $\sim 800$  kW beam power is expected.
- \* The power supply upgrade of horns, reinforcement of the horn strip-line cooling, DAQ and beam interlock upgrade are planned.

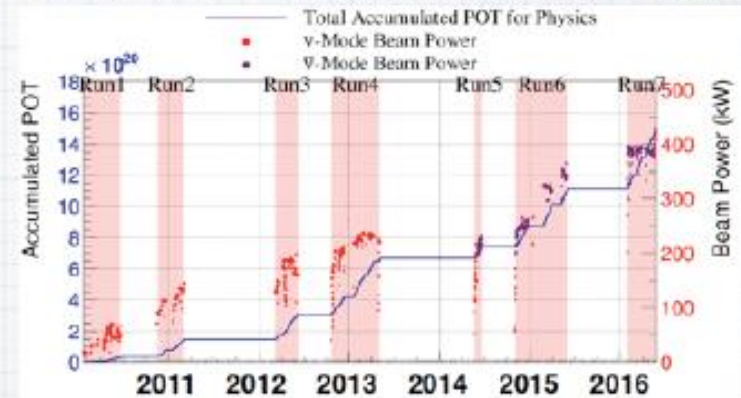

27 May 2016  
POT total:  $1.510 \times 10^{21}$

v-mode POT:  $7.57 \times 10^{20}$  (50.14%)  
v-mode POT:  $7.53 \times 10^{20}$  (49.86%)

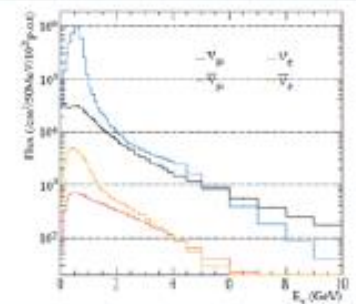
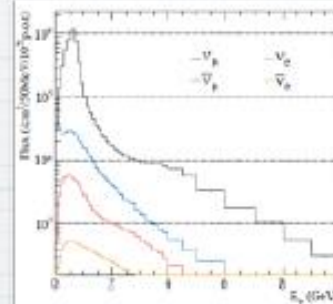

WG #1(Mon) T. Sekiguchi  
WG3 #2(Tue) K. Sakashita

# $\nu$ -beam facilities for LBL exp. in operation

- \* FNAL NuMI for NOvA
- \* OA beam : Neutrino Energy  $\sim 2\text{GeV}$
- \*  $\sim 600\text{kW}$  beam operation is achieved.
- \* Test operation of design beam power ( $700\text{kW}$ ) is also achieved in 2016.

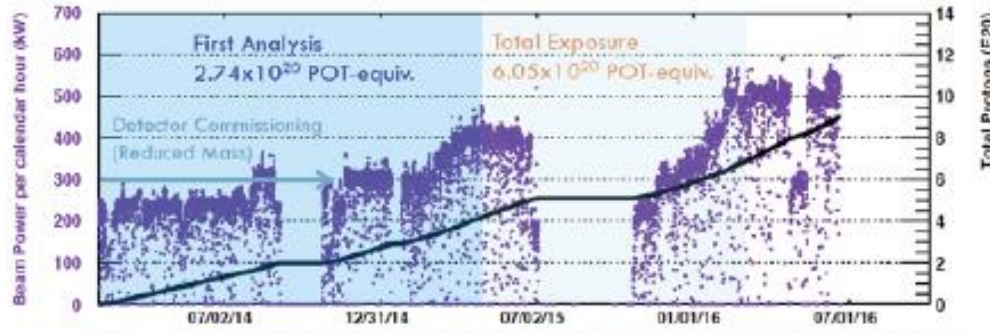
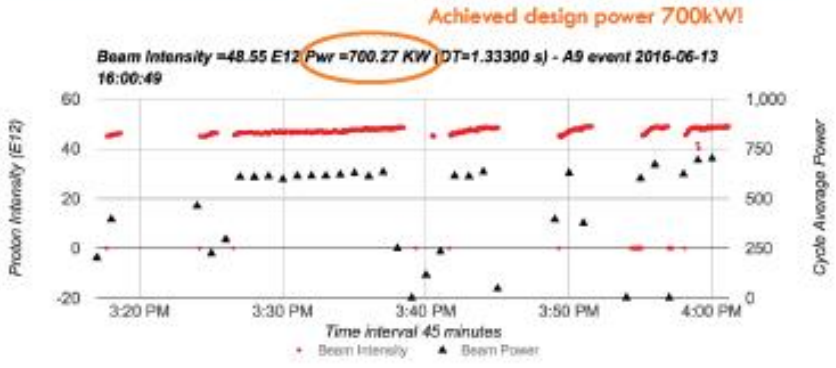
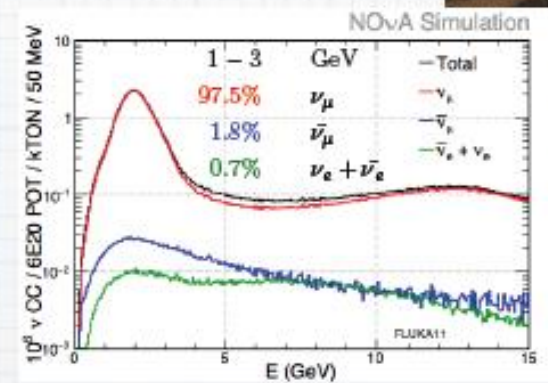
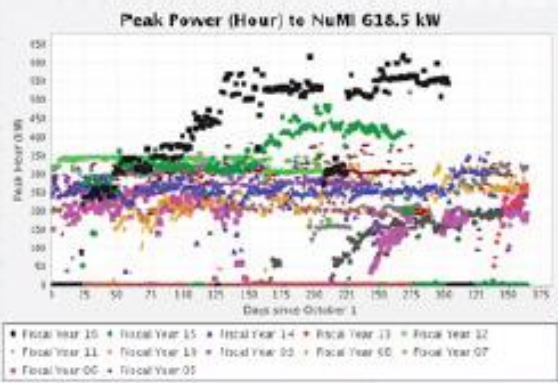
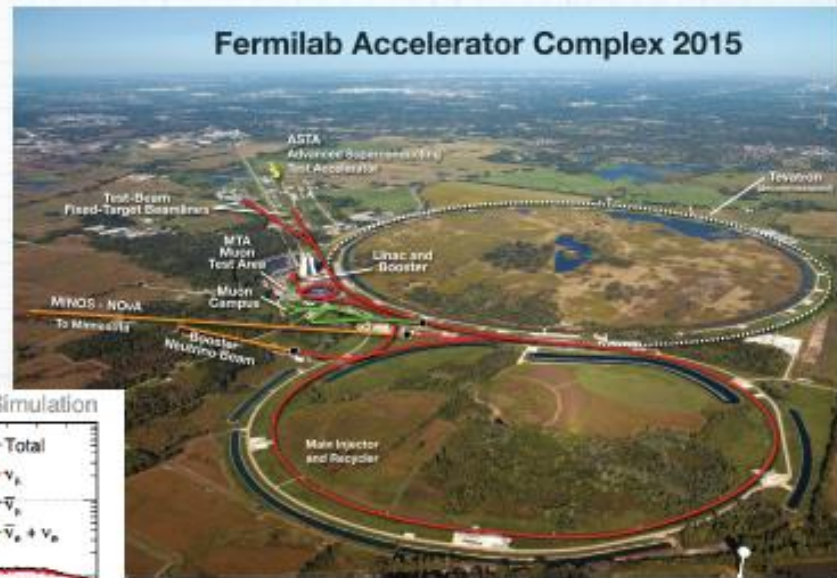

# Future proposal of $\nu$ -beam facilities

- \* FNAL LBNF for DUNE
- \* MI cycle: 1.33s  $\rightarrow$  1.2s
- \* MI Proton/pules:  $4.9 \times 10^{13} \rightarrow 7.5 \times 10^{13}$
- \* MI Beam power: 0.7  $\rightarrow$  1.2 MW
- \* The beamline is designed to be upgradeable up to 2.4 MW proton beam power.

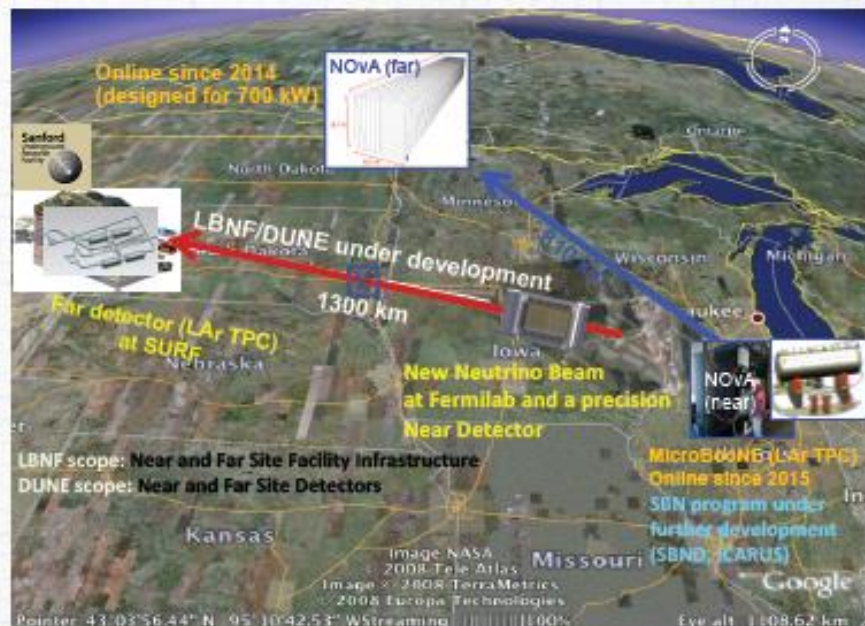

Designed to run at 1.2 MW beam power (PIP-II) and upgradeable to 2.4 MW

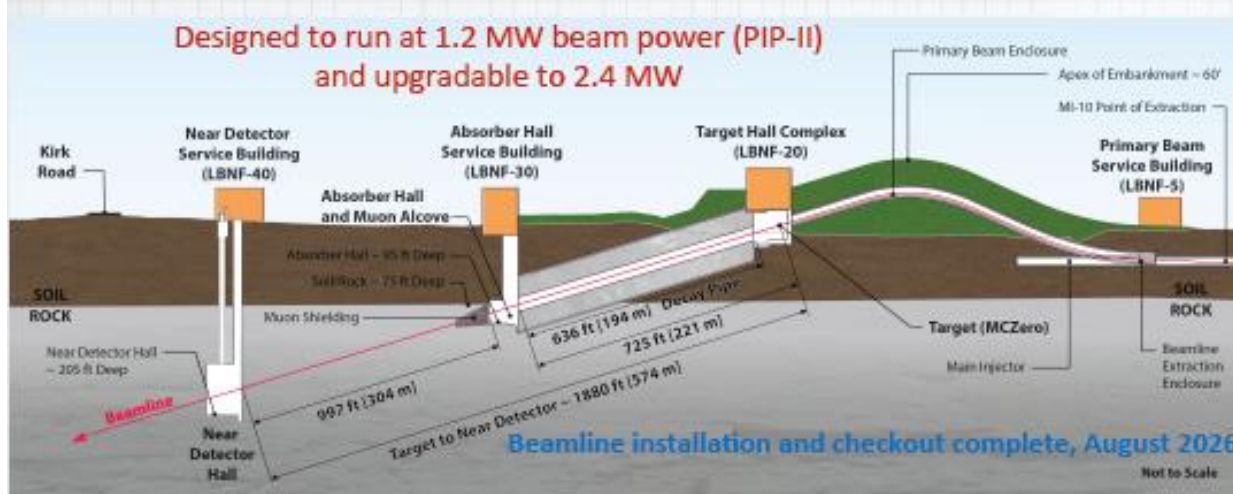

The PIP-II goal is to support long-term physics research goals by providing increased beam power to LBNF, while providing a platform for the future

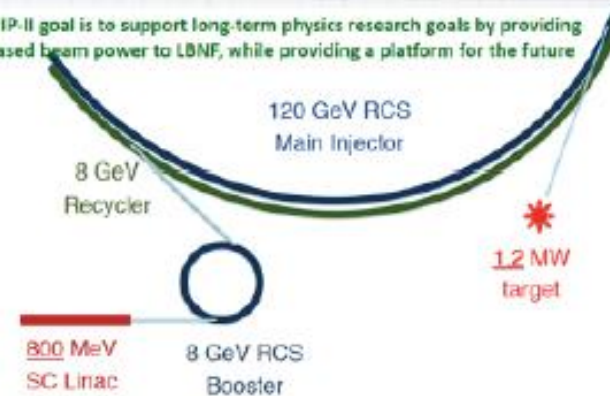

# Future proposal of $\nu$ -beam facilities: ESSnuSB

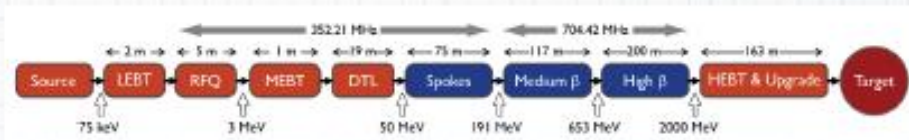

2GeV proton Linac : ready by **2023**

Beam power: **5 MW** .

14 Hz (2.86 ms,  $10^{15}$  protons/cycle).

Duty = 4%.

LINAC upgrade

- Doubled rate(14Hz→24Hz,Duty 4%→8%)
- Proton beam →  $H^-$  beam

Accumulation Ring ( for horn focusing)

- Beam pulse width 2.86 ms→ few  $\mu$ s

Conventional beam line with multiple horns  
(+Far detector)



Proton beam switch-yard

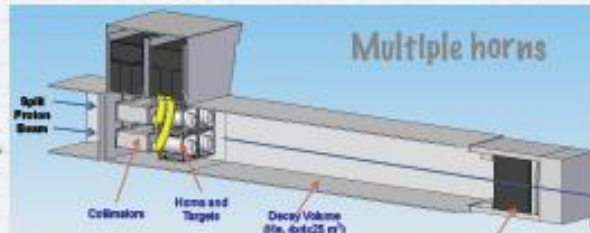

WG3 #3(Wed) N. Vassilopoulos

~300MeV neutrino beam

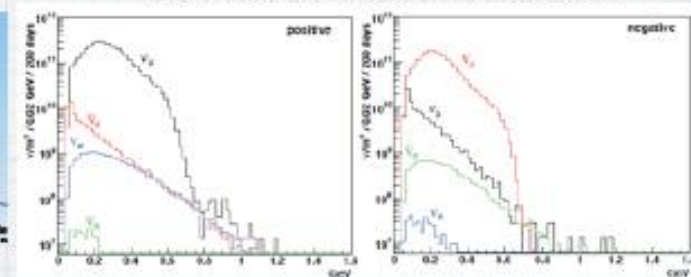



# Perspective

- $e/\mu$  identification in the liquid scintillator
  - MC studies are ongoing

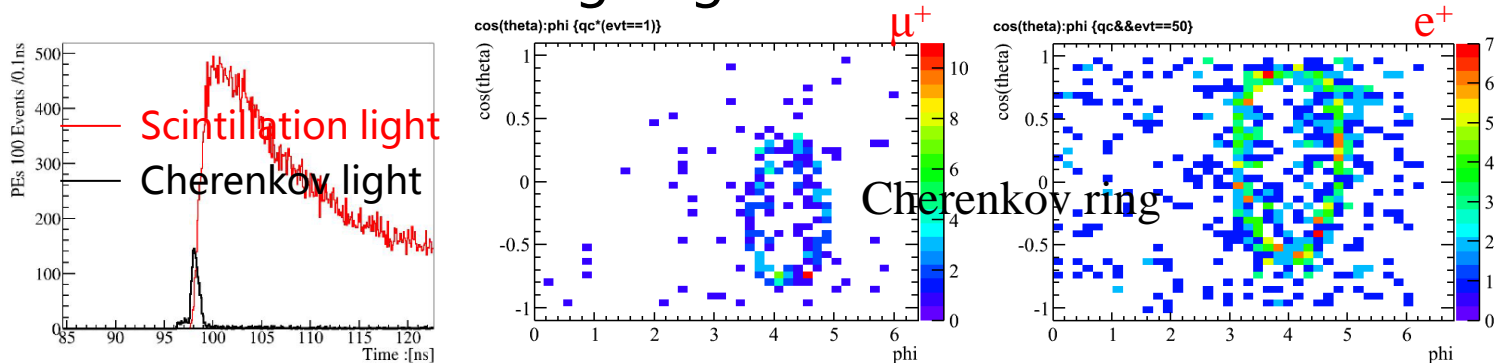

- Improve charge identification
  - A large magnetized detector?
- Reduce atmospheric background
  - Reconstructing neutrino direction
  - Sending neutrino in short bunches (arXiv:1511.02859)?

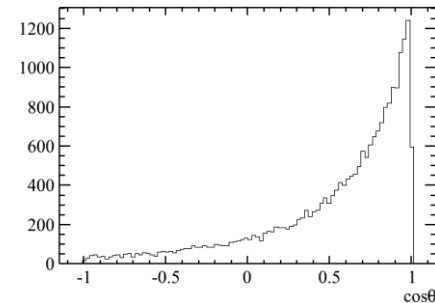

Direction of  $e^+$  from IBD

- **Not realistic** in ADS-type accelerator (CW beam)

# Results

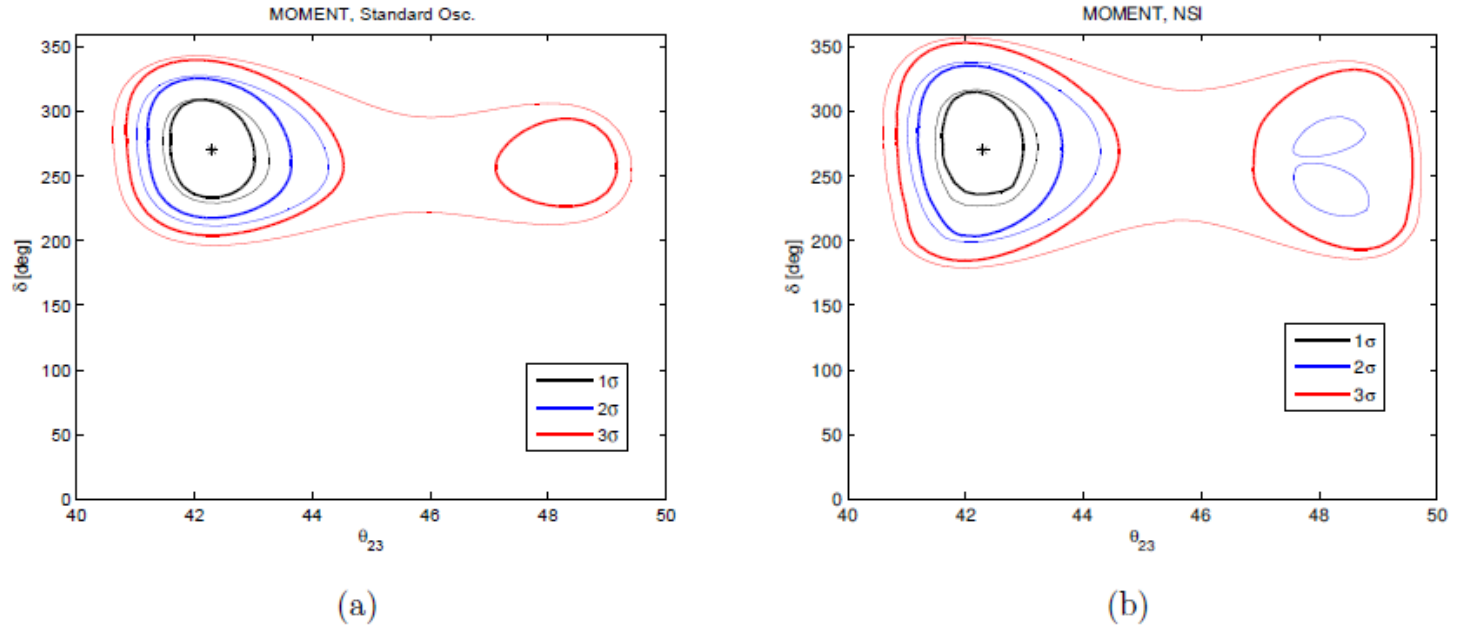

**FIG. 3.** Projected sensitivity of the MOMENT experiment on  $\delta - \theta_{23}$  for different background suppression factors  $SF=0.1\%$  and  $10\%$ , respectively shown with thick and thin lines. The true values of neutrino mass parameters are marked by a star and are set to their present best fit values [44]. Fig (a) shows the projected sensitivity assuming no NSI. In Fig (b), the present  $1\sigma$  uncertainty of all values of  $\epsilon$  [25] are taken into account.

# Towards High Intensity Neutrino Beams

- \* Running neutrino beam facilities have the prospects to their design beam power in a few years.
- \* NuMI: 700kW test was performed in 2016
- \* J-PARC- $\nu$ : 425kW operation was achieved. + J-PARC MR high repetition rate in 2018.
- \* Goal in coming decade: Real  $>1$ MW beam power
  - \* J-PARC- $\nu$ : Aiming  $\sim 1.3$ MW beam
  - \* FNAL PIP-II + LBNF: Aiming  $\sim 1.2$ MW beam
- \* Following future plan:  $\nu$ -beam with SC linac ( $>5$ MW)
  - \* Developing target+pion focusing device is key.
- \* Common technical challenges:

# Muon Accelerator Program (MAP)

## Muon based facilities and synergies

Mark Palmer

### Neutrino Factory (NUMA)

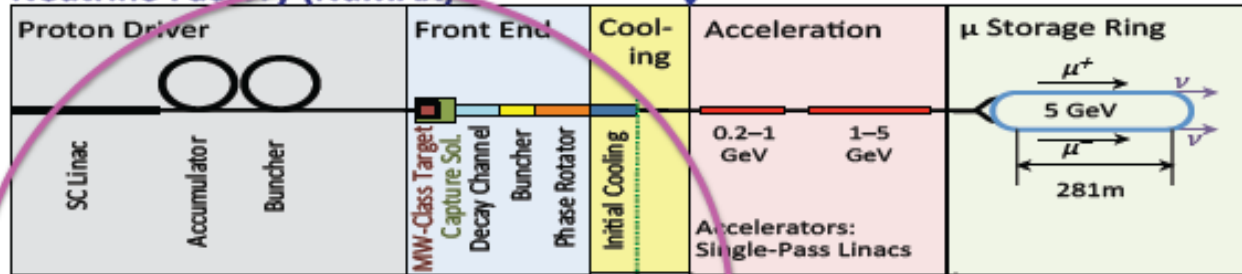

$\nu$  Factory Goal:  
 $10^{21}$   $\mu^+$  &  $\mu^-$  per year  
 within the accelerator acceptance

$\mu$ -Collider Goals:  
 126 GeV  $\Rightarrow$   
 $\sim 14,000$  Higgs/yr  
 Multi-TeV  $\Rightarrow$   
 Lumi  $> 10^{34}$  cm $^{-2}$ s $^{-1}$

Share same complex

### Muon Collider

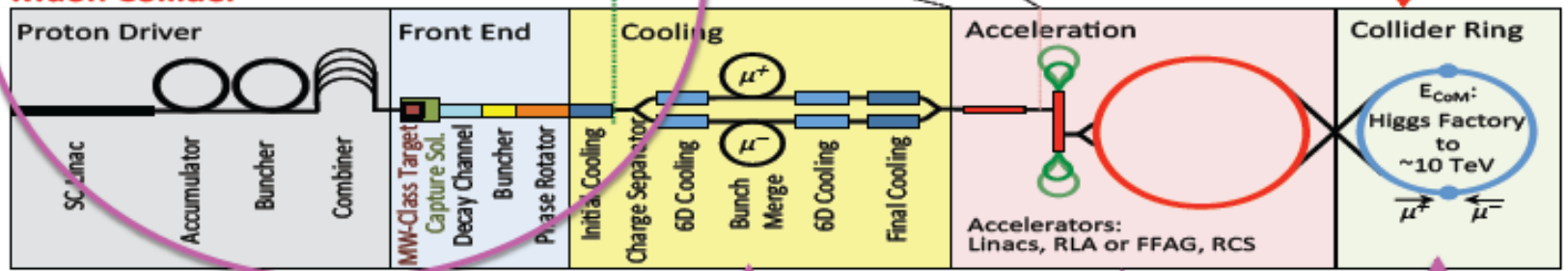

Key Challenges

- $\sim 10^{13}$ - $10^{14}$   $\mu$  / sec  
Tertiary particle  
 $p \rightarrow \pi \rightarrow \mu$ :
- Fast cooling ( $\tau=2\mu$ s)  
by  $10^6$  (6D)
- Fast acceleration  
mitigating  $\mu$  decay
- Background  
by  $\mu$  decay

Key R&D

- MW proton driver  
MW class target  
NCRF in magnetic field
- Ionization cooling  
High field solenoids (30T)  
High Temp Superconductor
- Cost eff. low RF SC  
Fast pulsed magnet  
(1kHz)
- Detector/  
machine  
interface

JP.Delahaye

Unique properties of muon beams (Nov 18,2015)



# A Staged Muon Vision

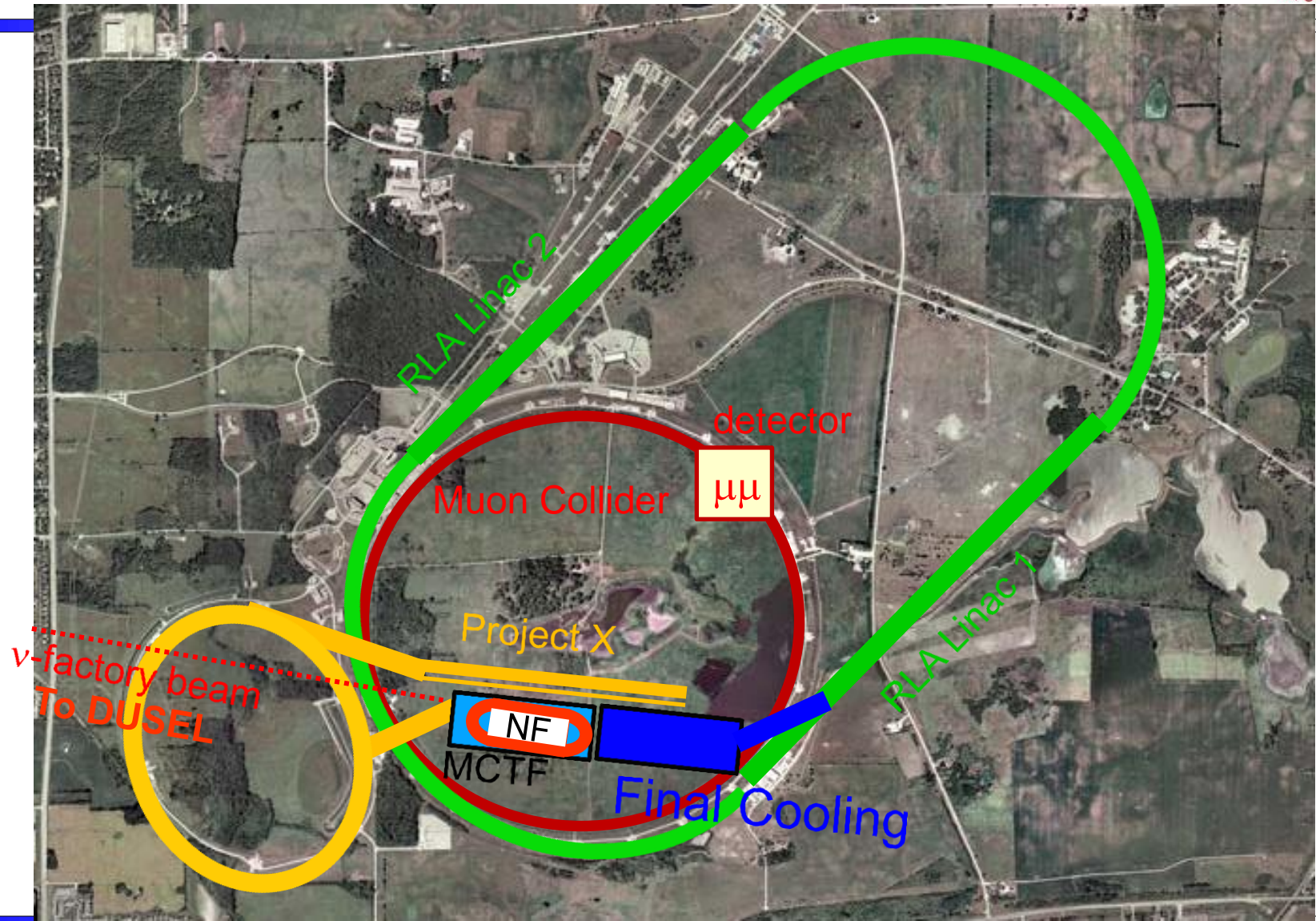



# Sterile Neutrino Search

Potential sterile mediated  $\bar{\nu}_e \rightarrow \bar{\nu}_e$  disappearance measured in reactor experiments are sensitive to  $\theta_{14}$

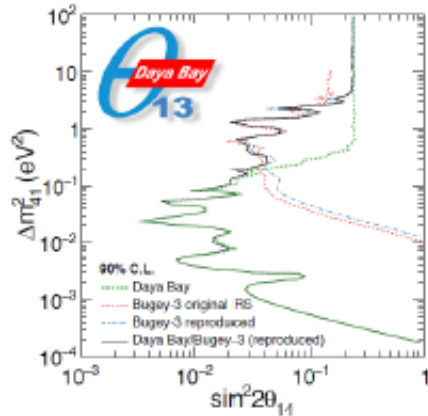

Combine  
Daya Bay  
&  
MINOS

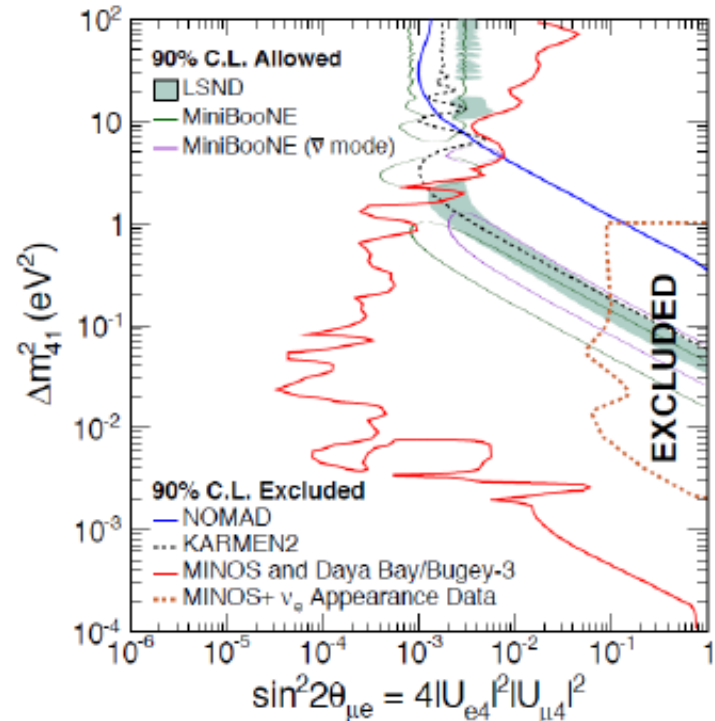
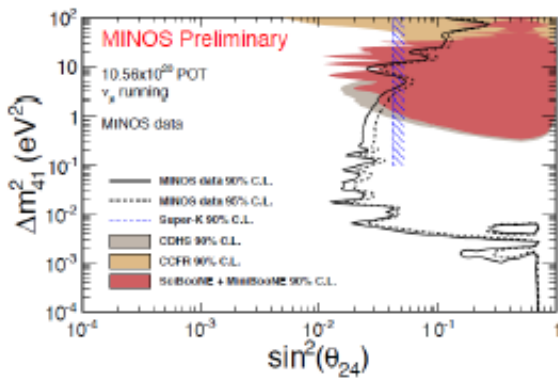

# SHiP: Search for Hidden Particles

- SHiP is a new proposed experiment at the CERN SPS, aiming to search for neutral hidden particles with mass up to  $\mathcal{O}(10)$  GeV and extremely weak couplings, down to  $10^{-10}$ .
- production and decay of hidden particles:



- large decay volume followed by spectrometer, calorimeter, PID
  - shielding from SM particles: hadron absorber + VETO detectors
- High intensity 400 GeV beam dump  $\implies$  high flux of neutrinos (all species).
  - More details: [arXiv:1504.04956](https://arxiv.org/abs/1504.04956) (TP) and [arXiv:1504.04855](https://arxiv.org/abs/1504.04855)

# Neutrino Summary

- Oscillation experiments:
  - High energy neutrino: Nova, T2K, DUNE, T2HK
    - multi GeV? 1~2MW
    - Bunched, SF requirement not clear
  - Medium/low energy neutrino: ESSnuSB/MOMENT
    - 1~2 GeV, >5MW
    - Bunched! SF 0.1% for MOMENT (0.01% in ProjectX)
  - Neutrino factory (muon collider)
    - Over MW source + ...
- Sterile neutrino: Nova, T2K
  - Similar to LBNE
- Heavy neutrino
  - up to 400 GeV proton

# Physics with Proton Sources

- Neutrino Physics
  - Neutrino Oscillation
  - Sterile Neutrino
  - Heavy Neutrino
- Muon Physics
  - CLFV
  - $g-2$
  - $\mu$ EDM
  - Precision Measurements
- Kaon/Pion Physics
  - $K \rightarrow \pi, \nu, \nu$
- Neutron Physics
  - nEDM

# Muon Physics: Worldwide Effort

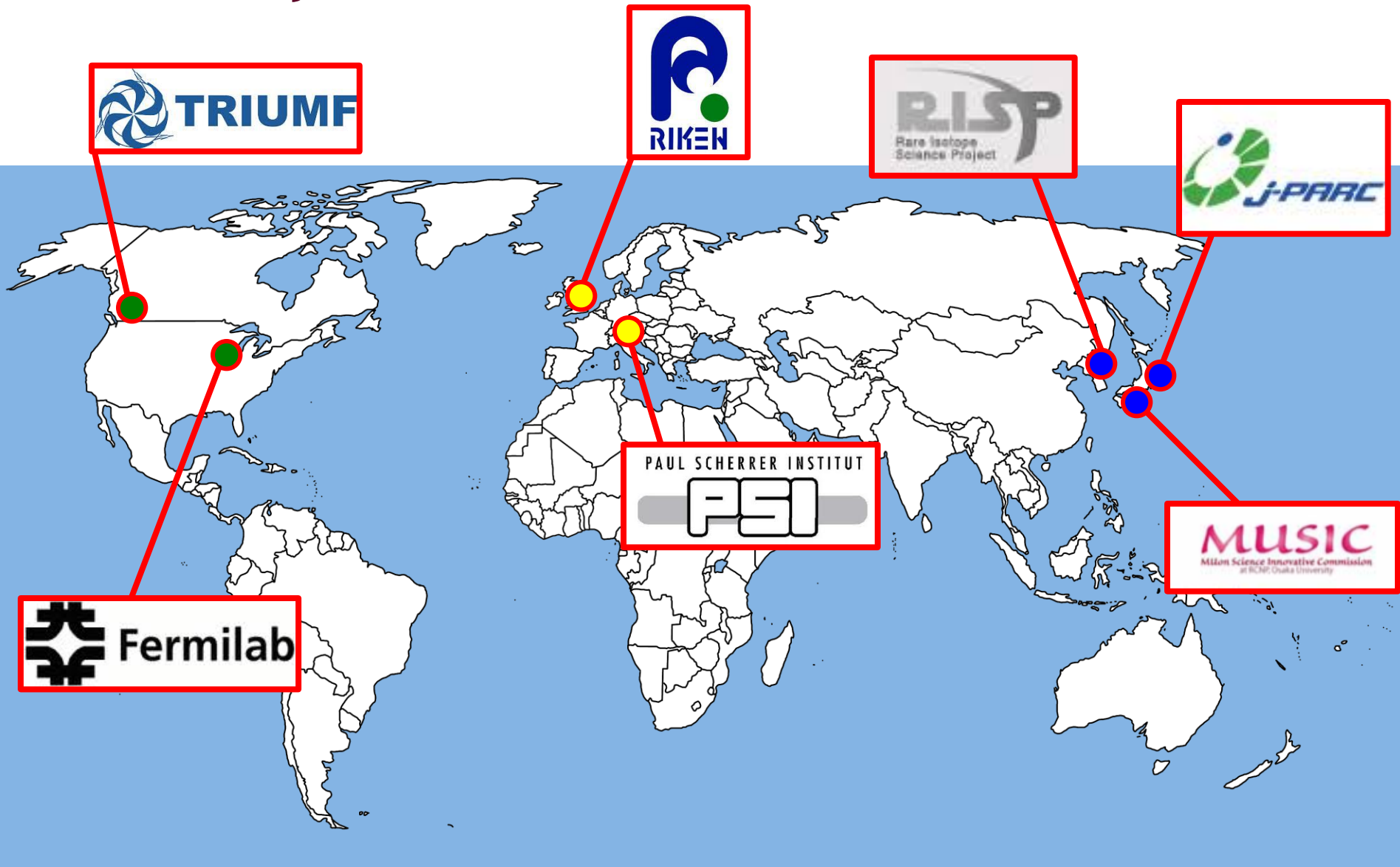

# Muon Physics: Worldwide Effort\*

- Lifetime – Fermi constant
  - [MuLan & FAST](#) at PSI
- Decay parameters ( $\rho, \delta, \eta, P_{\mu\xi} \dots$ )
  - [TWIST](#) at TRIUMF and [polarization measurements](#) at PSI
- Muon Capture
  - [MuCap](#) at PSI:  $g_p$ , pseudoscalar coupling
  - [MuSun](#) at PSI: basic EW interaction in 2N system
- Lepton Flavor Violation
  - $\mu \rightarrow e\gamma$  – [MEG](#) and  [\$\mu 3e\$](#)  at PSI
  - $\mu e$  conversion: [Mu2e](#) (FNAL), [COMET](#), [DeeMee](#) (JPARC)
- Anomalous magnetic moment ( $g-2$ )
  - [E821](#) at BNL and [Muon  \$g-2\$](#)  at FNAL & JPARC
- Search for Electric Dipole Moment
  - [E821](#) at BNL and [Muon  \$g-2\$](#)  at FNAL & JPARC
- Lorentz / CPT violation tests
  - [E821](#) at BNL and [Muon  \$g-2\$](#)  at FNAL & JPARC
- Proton charge radius
  - [Muonic Lamb shift \(CREMA\)](#), [MuSE](#) at PSI
- Muonium Spectroscopy
  - [Muonium hyperfine](#) at LAMPF & [MuSEUM](#) at JPARC
- ...

\* Incomplete list of [past](#), [present](#) & [future](#) muon experiments

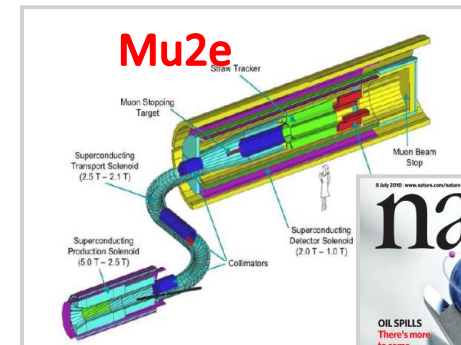
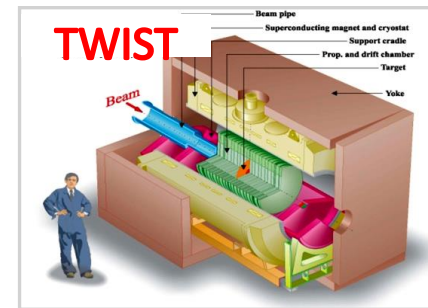

# Different categories of muon experiments

1. Measurement of SM parameters like with other particles:
  - Masses:  $M_Z$   $M_W$   $M_H$   $m_b$   $m_t$   $m_e$   $m_u$   $m_\nu$  ...
  - Couplings:  $\alpha_{\text{QED}}$   $\alpha_{\text{Strong}}$   $G_F$   $G_{\text{grav}}$
  - Structure of interactions:  $SU(3)_C \times SU(2)_L \times U(1)_Y$
2. Search for Physics Beyond the Standard Model (BSM):
  - Test for **deviations** from a pure **V-A structure**
  - Charged Lepton Flavor violation (CLFV) (see talk by S. Mihara)
  - **Searches** for **new particles** through quantum loop effects
3. Applied material research:
  - Muon spin Resonance (muSR) to probe magnetic properties

# The MuLan concept in one slide...

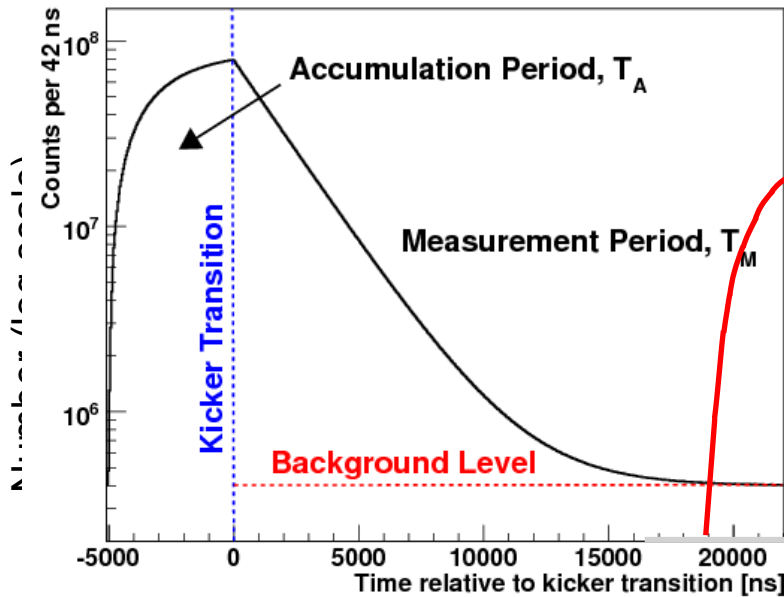

- Collect  $10^{12}$  decay electrons
- Fit decay spectrum to extract  $\tau_\mu$
- Avoid “early-to-late” systematics

$\tau_{\mu^+} = 2196980.3 \pm 2.2 \text{ ps}$

$G_F = 1.1663818(7) \times 10^{-5} \text{ GeV}^{-2} \text{ (0.6 ppm)}$

D.B. Chitwood et al., Phys. Rev. Lett. 99, 03201 (2007)  
 D. Webber et al., Phys. Rev. Lett. 106, 041803 (2011)  
 Tishchenko et al., Phys. Rev. D. 87, 052003 (2013)

Fill Period

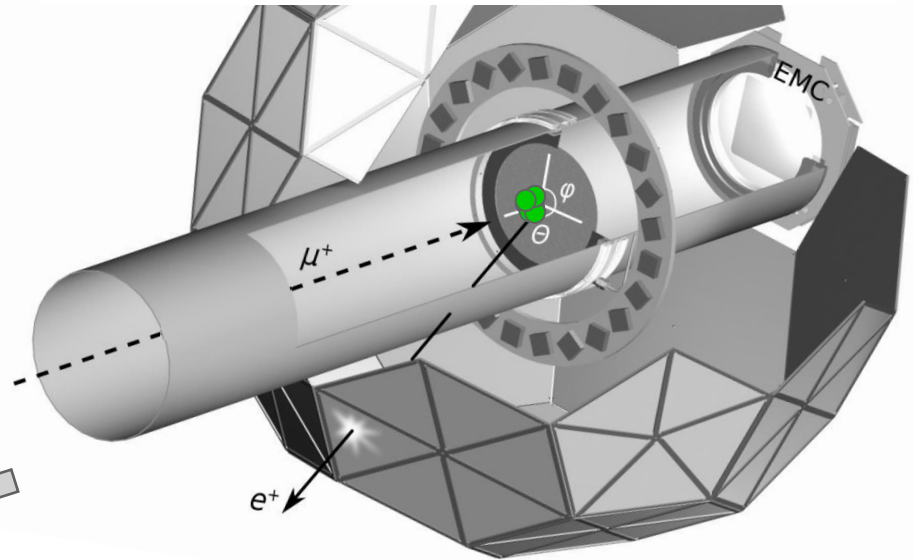
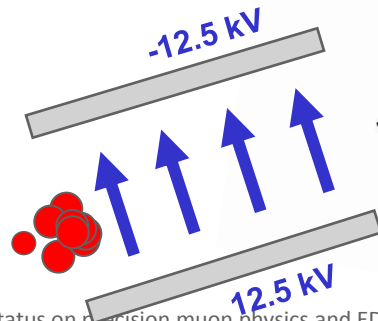

# MuCap: Measuring the nucleon structure

- MuLan result  $\lambda_{\mu^+} = 1/\tau_{\mu^+}$  is input for MuCap
- Form muonic hydrogen  $\mu^-p$  in ultra-pure hydrogen TPC
- Measure disappearance rate  $\lambda_{\mu^-}$
- Extract singlet capture rate  $\Lambda_S \approx \lambda_{\mu^-} - \lambda_{\mu^+}$
- Determine the nucleon's pseudo-scalar form factor  $g_p$

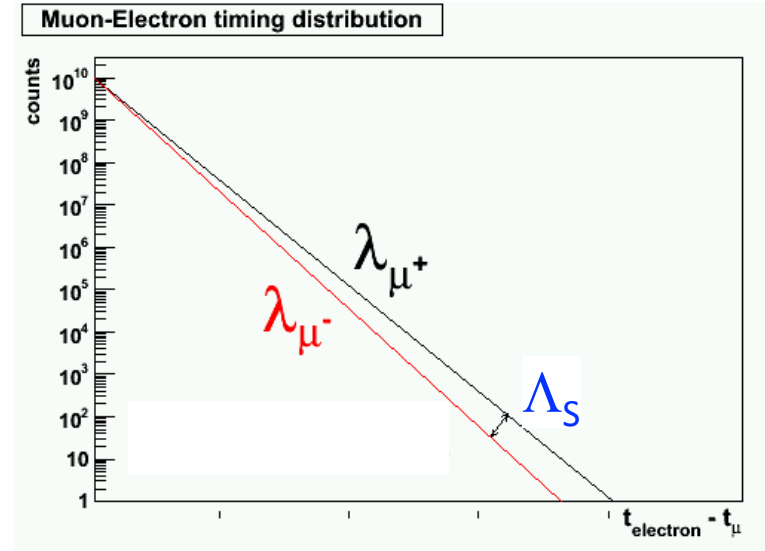
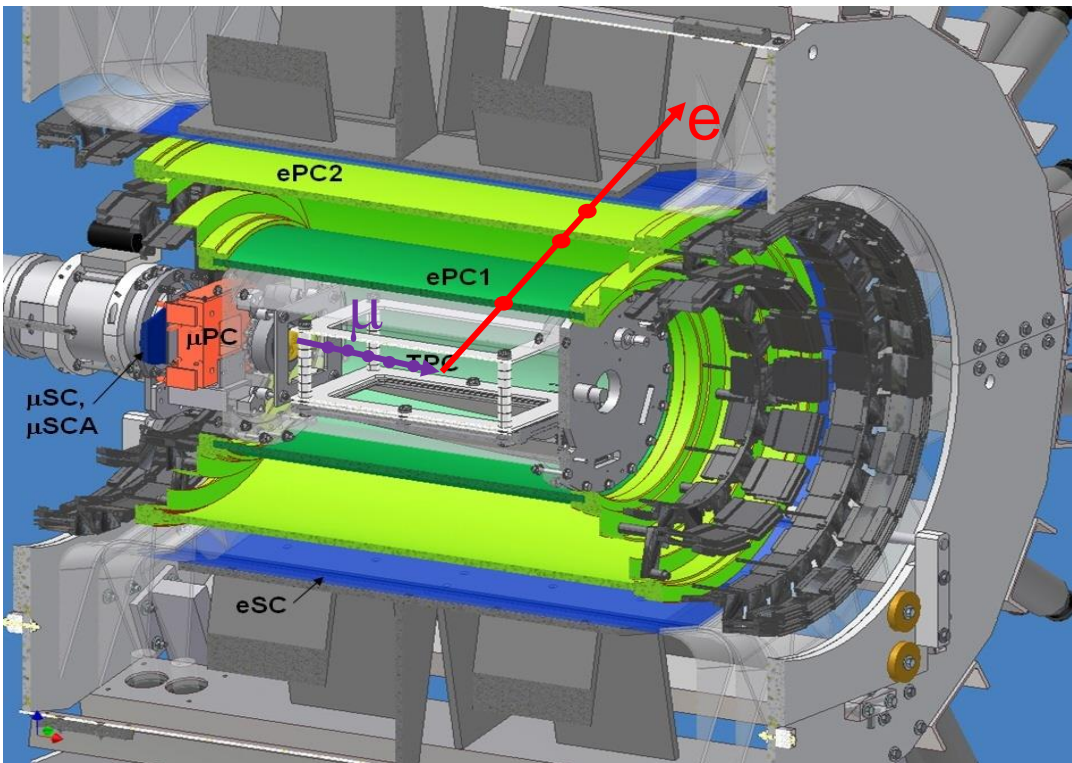
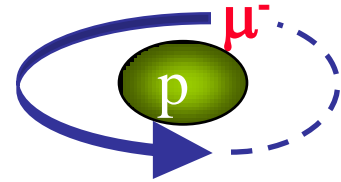

# MuCap: Muon capture on the proton

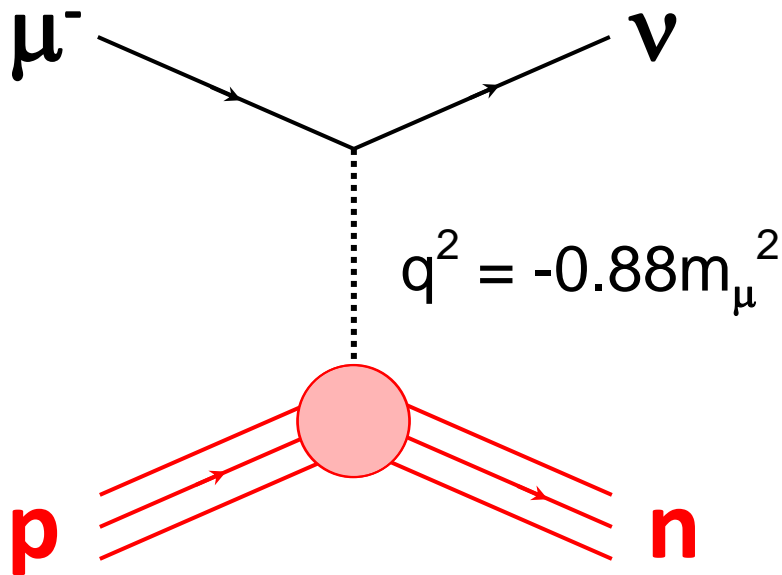

$$M \sim G_F V_{ud} \cdot \bar{\psi}_\nu \gamma_\alpha (1 - \gamma_5) \psi_\mu \cdot \bar{\psi}_n (V^\alpha - A^\alpha) \psi_p$$

$$V^\alpha = g_V(q^2) \gamma^\alpha + i g_M(q^2) \sigma^{\alpha\beta} q_\beta / 2M_N$$

$$A^\alpha = g_A(q^2) \gamma^\alpha \gamma_5 + g_P(q^2) q^\alpha / m_\mu \gamma_5$$

- Since  $g_V$ ,  $g_M$ ,  $g_A$ , and  $V_{ud}$  are well known,  $\Lambda_S$  determines the pseudo-scalar form factor  $g_P$
- Test of  $\chi$ PT theory prediction

$$g_P(\text{MuCap}) = 8.06 \pm 0.55$$

Andreev et al., Phys. Rev. Lett. 110, 012504 (2013)

$$g_P(\chi\text{PT theory}) = 8.26 \pm 0.23$$

# MuSun: Muon capture on the deuteron

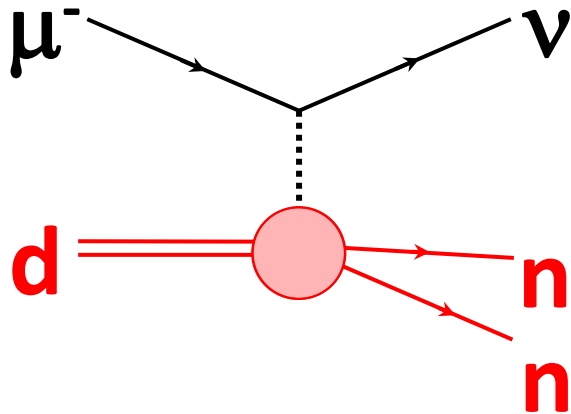

- Next step: Measure simplest **two-body** system
- EFT relates this process to **low energy constant  $\hat{d}_R$**  relevant for **other processes**
- Similar to MuCap with **ultra-pure deuterium, cryo-TPC (30K)**
- Data taking mostly completed, **analysis ongoing**

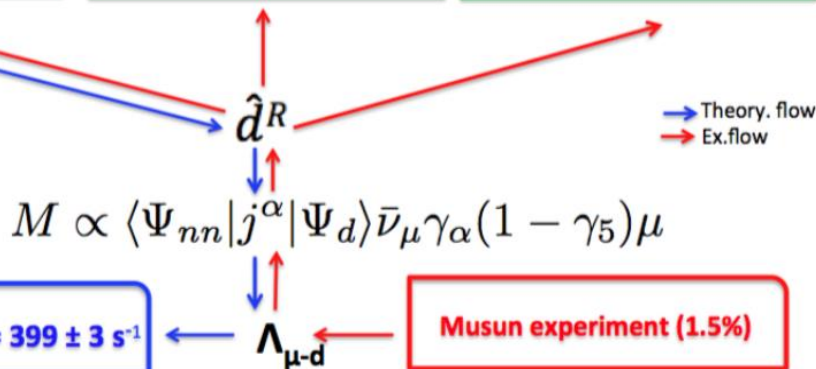
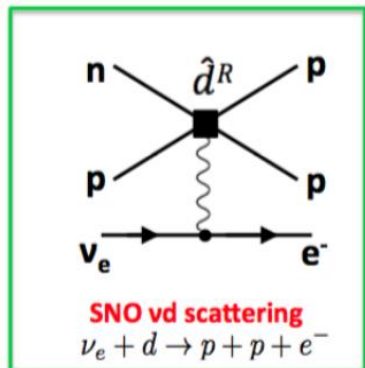
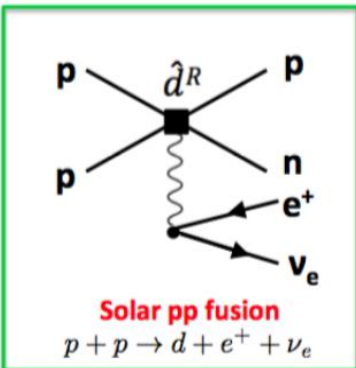
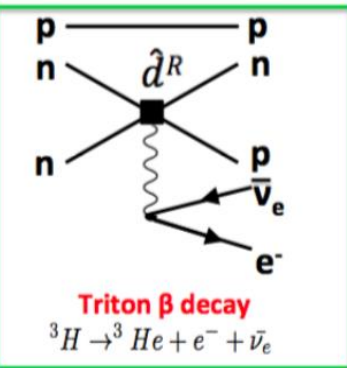

**Latest result:  $\Lambda_d = 399 \pm 3 \text{ s}^{-1}$**

**Musun experiment (1.5%)**

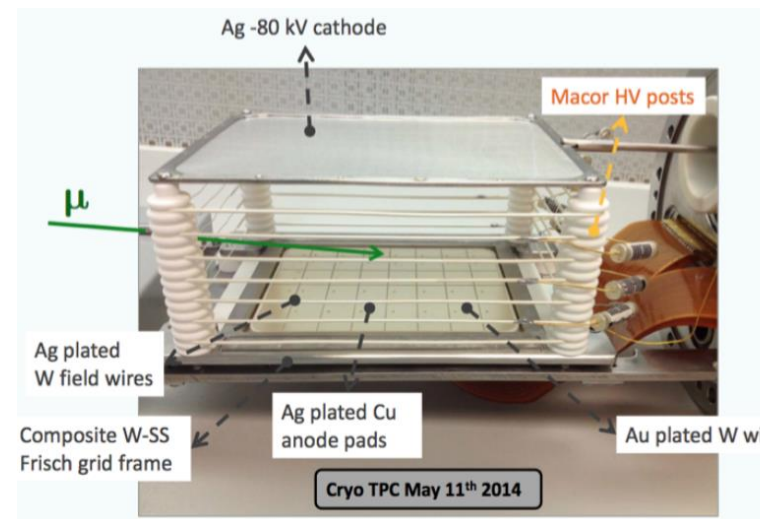

just 25, 2016

# Muonic Hydrogen Lamb Shift - Proton Charge Radius

- Bohr radius in muonic hydrogen is smaller by  $m_{\text{red}} = 186m_e$  than in hydrogen
- The muon overlap with the proton is larger by  $m_{\text{red}}^3$  and hence  $\mu p$  is more sensitive to the proton's charge distribution
- Extract proton charge radius  $r_p$  from  $2S - 2P$  transition (Lamb shift)

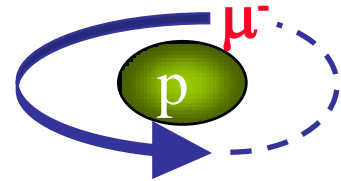

$$\Delta E(2S - 2P) = 209.978(5) - 5.226 r_p^2 + 0.0347 r_p^3 \quad \text{meV}$$

- Knowledge of the charge and magnetic distributions inside the proton are needed for precision tests of bound-state QED



# MUSE @ PSI

$r_p$ (fm)	electron	muon
spectroscopy	$0.877 \pm 0.007$	$0.841 \pm 0.0004$ ( $\mu p$ ) $0.8356 \pm 0.0020$ ( $\mu d + iso$ )
scattering	$0.875 \pm 0.006$	?

- New experiment at PSI to measure low-energy scattering of  $\mu^\pm p$  and  $e^\pm p$
- Goal:  $\Delta r_p \approx 0.007$  fm (similar to current CODATA)

$\theta \approx 20^\circ - 100^\circ$   
 $Q^2 \approx 0.002 - 0.07 \text{ GeV}^2$   
 5 MHz total beam flux  
 $\approx 2-15\% \mu$ 's  
 $\approx 10-98\% e$ 's  
 $\approx 0-80\% \pi$ 's

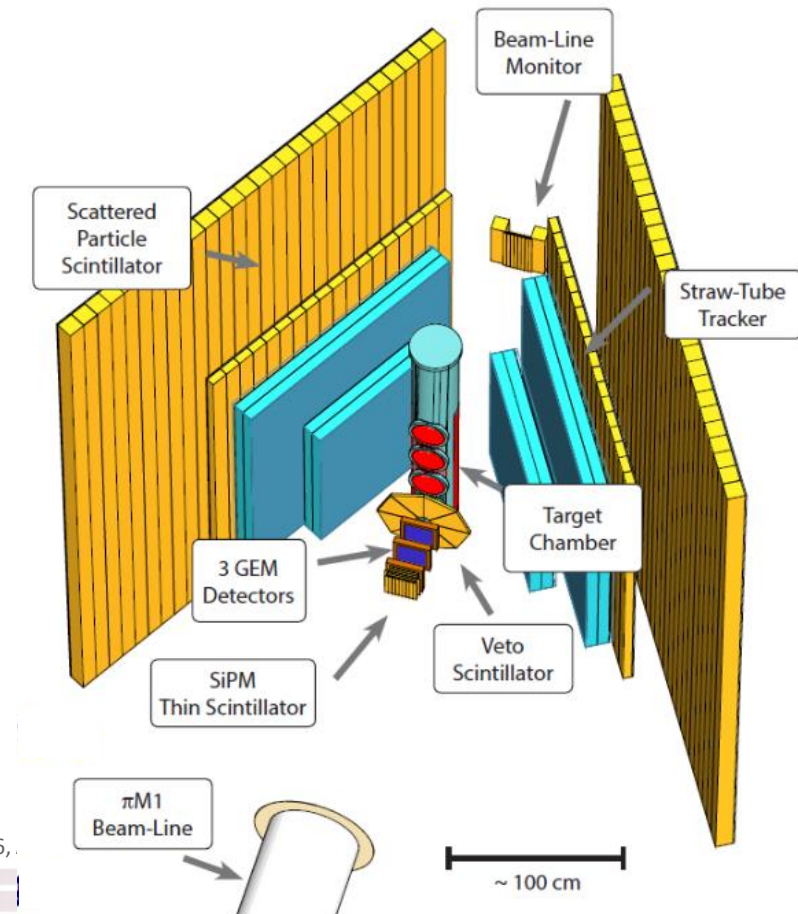

# Muon g-2: Motivation measuring $a_\mu = (g-2)/2$

$$\text{BNL: } a_\mu^{\text{Expt.}} - a_\mu^{\text{SM}} = (260 \pm 78) \times 10^{-11} \quad (3.3 \sigma)$$

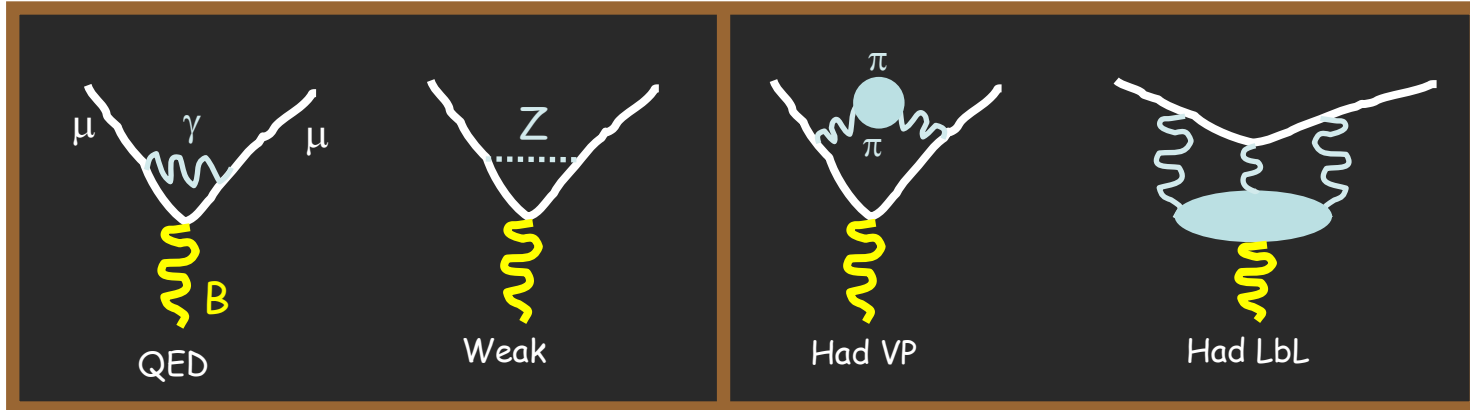

Known well beyond current experimental precision

Known slightly better than current experimental precision – needs work

$$a_\mu^{\text{Expt.}} = a_\mu^{\text{SM}} + a_\mu^{\text{New Physics}}$$

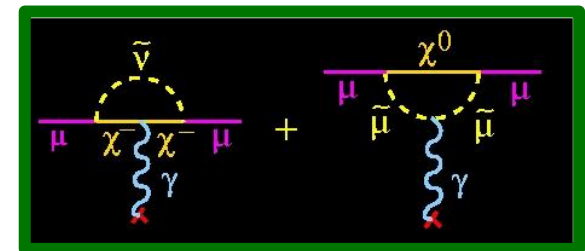

???

- If **current discrepancy remains** new experiments would yield  $>5\sigma$
- Together **with theory improvements** could give  $>8\sigma$

# Muon g-2: The basic measurement

→ Momentum  $p$

→ Spin  $S$

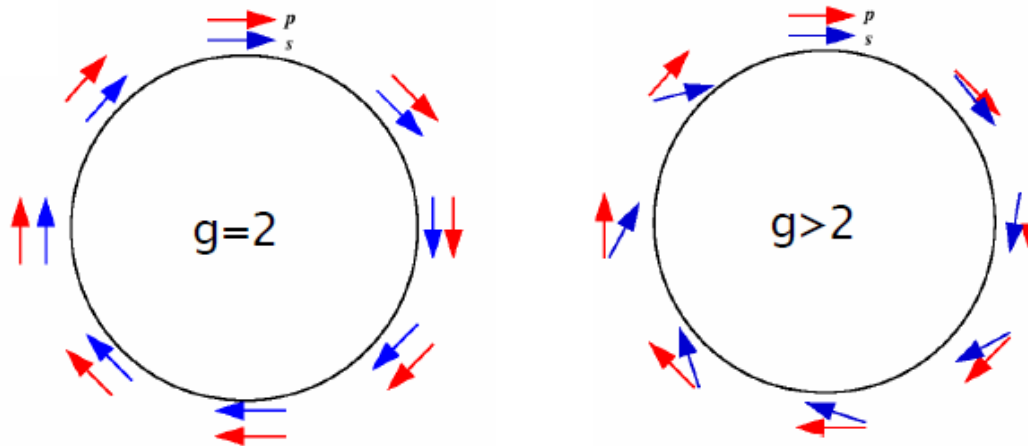

$$\omega_a = e/m \mathbf{a}_\mu \mathbf{B}$$

Determination of  $\mathbf{a}_\mu$  requires measurement of **both**

1. the spin precession frequency  $\omega_a$
2. the magnetic field  $\mathbf{B}$

# The new Muon g-2 experiments: A comparison

See also WG4 talks today:

- R. Kitamura @ 10:45am
- W. Gohn @ 11:15am

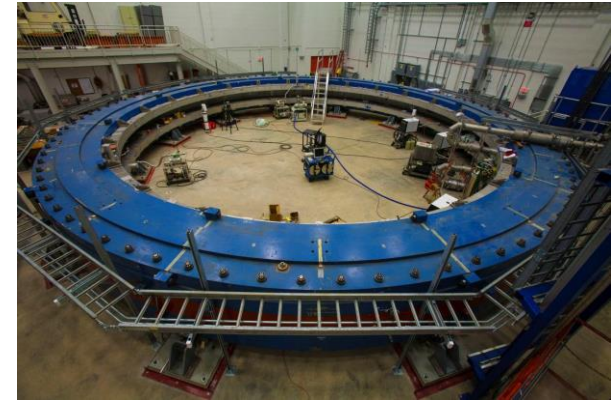
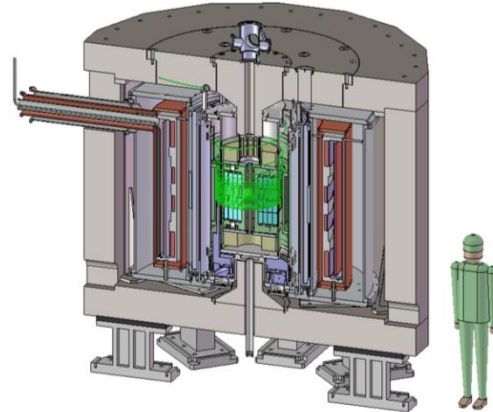

	E34 @ JPARC	E989 @ Fermilab
Beam	High-rate, ultra-cold muon beam ( $p = 300 \text{ MeV}/c$ )	High-rate, magic-momentum muons ( $p = 3.094 \text{ GeV}/c$ )
Polarization	$P_{\text{max}} = 50\%$	$P \approx 97\%$
Magnet	MRI-like solenoid ( $r_{\text{storage}} = 33\text{cm}$ )	Storage ring (7m radius)
B-field	3 Tesla	1.45 Tesla
B-field gradients	Small gradients for focusing	Try to eliminate
E-field	None	Electrostatic quadrupole
Electron detector	Silicon vanes for tracking	Lead-fluoride calorimeter
B-field measurement	Continuous wave NMR	Pulsed NMR
Current sensitivity goal	400 ppb	140 ppb

# ThO EDM excludes certain SM extensions

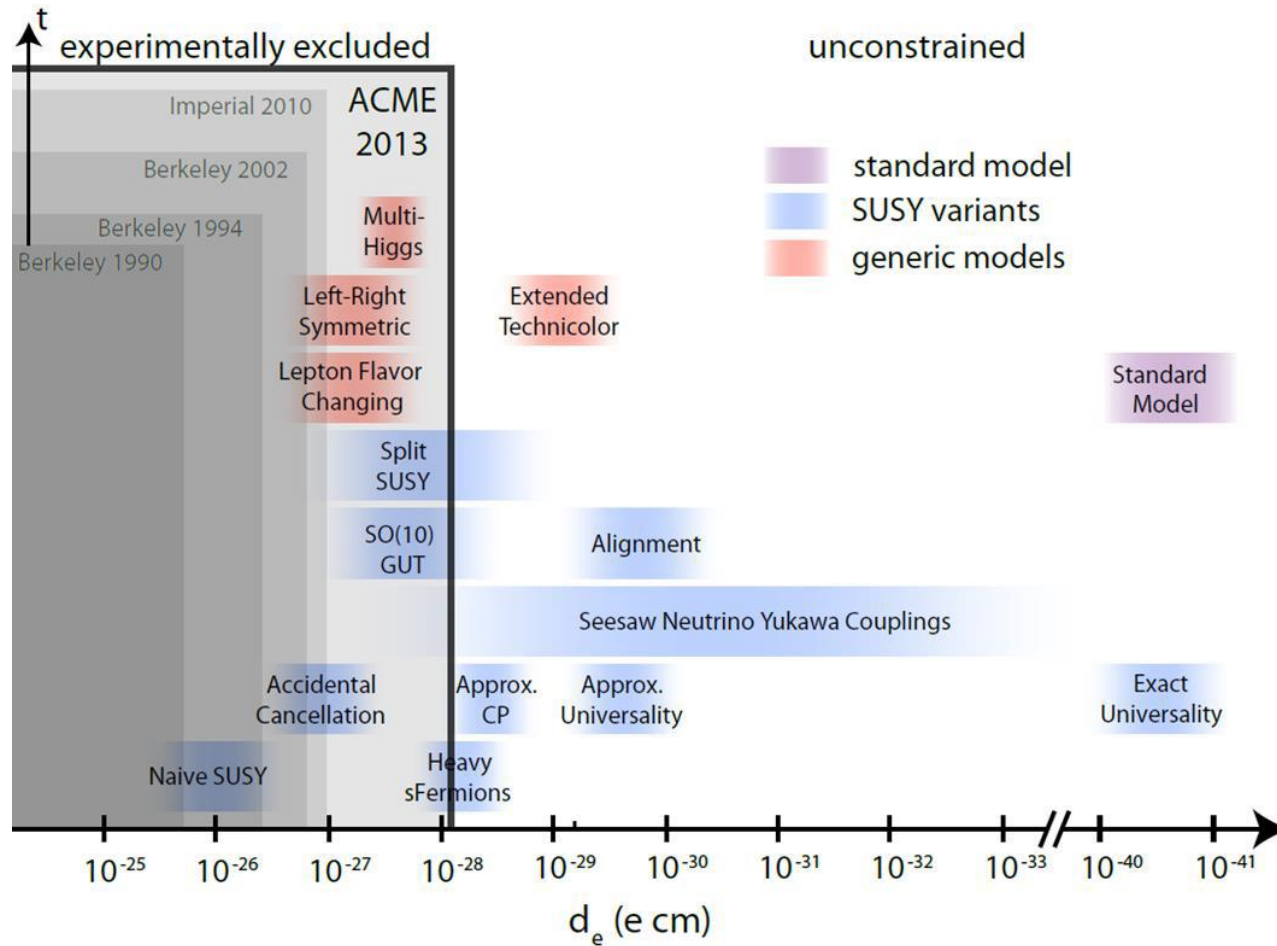

# Why CLFV

- Flavor is one of the **most puzzling** aspects of the SM.
  - Why 3 generations? Mass? Mixing?
- We have observed **quark mixing** and **neutrino oscillation**, but no **charged flavor violation** so far.
  - **Will tell us more about the nature of flavor BSM!**

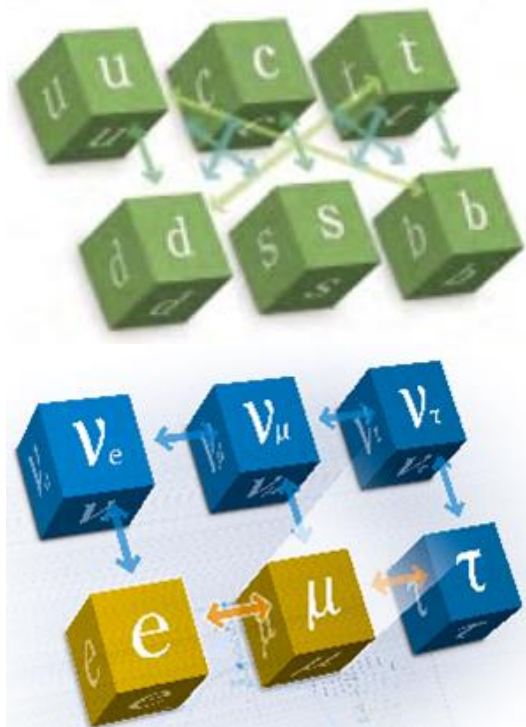

- Quark flavor violation:
  - Characterized by CKM matrix
- Neutral lepton flavor violation:
  - Characterized by PMNS matrix
- Charged lepton flavor violation?
  - Will help to solve flavor puzzle!

# CLFV as a Probe to New Physics

- Is CLFV allowed in SM?

- Through loop diagram with neutrino oscillation, yes. But...

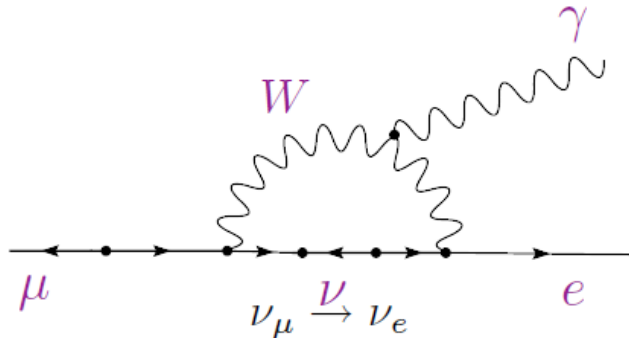

$$\mathcal{B}(\mu \rightarrow e\gamma) = \frac{3\alpha}{32\pi} \left| \sum_{i=2,3} U_{\mu i}^* U_{ei} \frac{\Delta m_{i1}^2}{M_W^2} \right|^2 \sim 10^{-54}$$

\* Historically we define:  $Br = \Gamma_{CLFV} / \Gamma_{capture}$

**Practically negligible.**

**Clean probe to NP!**

- How about with New Physics?

- Assuming TeV scale new physics, naturally large coupling constant like SUSY, it may happen just around the corner!

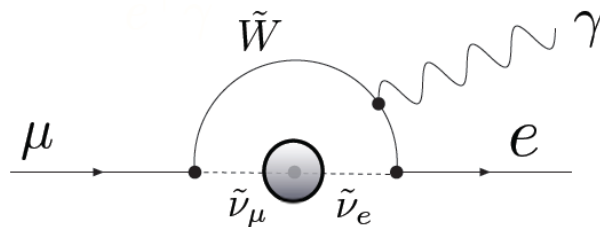

$$Br(\mu \rightarrow e\gamma) = 10^{-11} \times \left(\frac{2\text{TeV}}{\Lambda}\right)^4 \left(\frac{\theta_{\mu e}}{10^{-2}}\right)^2$$

**$10^{-11} \sim 10^{-15}$  level.**

**Reachable with current technics!**

# CLFV candidates

- CLFV in  $\tau$  sector:
  - Studied in B factories: LHCb, BaBar, Belle
  - Will see improvement in Belle II and LHCb
- CLFV in  $\mu$  sector:
  - Studied at PSI.  $\mu \rightarrow e\gamma$  is the best result.
  - Will see **great improvement** in  $\mu N \rightarrow eN$  at J-PARC and FermiLab
- $\tau$  intensity:
  - Current: 2/sec
  - Future: 100/sec
- $\mu$  intensity:
  - Current  $10^8$ /sec
  - Future:  $10^{11} \sim 10^{12}$ /sec

Reaction	Current Limit	Future Limit	Location
$\tau \rightarrow \mu\gamma$	$4.4 \times 10^{-8}$	$< 10^{-9}$	Flavor factory
$\tau \rightarrow e\gamma$	$3.3 \times 10^{-8}$	$< 10^{-9}$	Flavor factory
$\tau \rightarrow \mu\mu\mu$	$2.1 \times 10^{-8}$	$< 10^{-9} \sim 10^{-10}$	Flavor factory
$\tau \rightarrow eee$	$2.7 \times 10^{-8}$	$< 10^{-9} \sim 10^{-10}$	Flavor factory
$\tau \rightarrow \mu ee$	$1.5 \times 10^{-8}$	$< 10^{-9} \sim 10^{-10}$	Flavor factory
$\mu \rightarrow e\gamma$	$4.3 \times 10^{-13}$	$4 \times 10^{-14}$	MEG II
$\mu \rightarrow eee$	$1 \times 10^{-12}$	$10^{-15} \sim 10^{-16}$	mu3e/MuSIC
$\mu N \rightarrow eN$ (Au)	$7 \times 10^{-13}$	$< 10^{-18}$	PRISM/Mu2e II
$\mu N \rightarrow eN$ (Al)	--	$10^{-15}/10^{-17}$	COMET/Mu2e
$\mu N \rightarrow eN$ (Ti)	$4.3 \times 10^{-12}$	$< 10^{-18}$	PRISM/Mu2e II
$\mu^- N \rightarrow e^+ N$ (Al)	$4.3 \times 10^{-12}$	?	COMET
$\mu^+ e^- \rightarrow \mu^- e^+$	$8.3 \times 10^{-11}$	?	COMET

# Model Independent Approach for CLFV

$$L = \frac{m_\mu}{(\kappa+1)\Lambda^2} \bar{\mu}_R \sigma_{\mu\nu} e_L F^{\mu\nu} + \frac{\kappa}{(\kappa+1)\Lambda^2} \bar{\mu}_L \gamma_\mu e_L \sum_{q=u,d} \bar{q}_L \gamma_\mu q_L$$

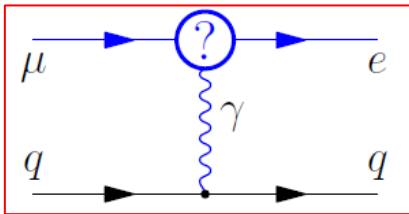

Photonic Process  
 $\kappa \ll 1$

$\mu \rightarrow e\gamma$	$\mu - e$
Strong	Yes

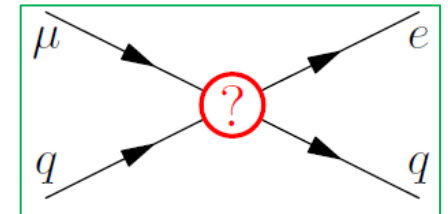

Four-Fermi Process  
 $\kappa \gg 1$

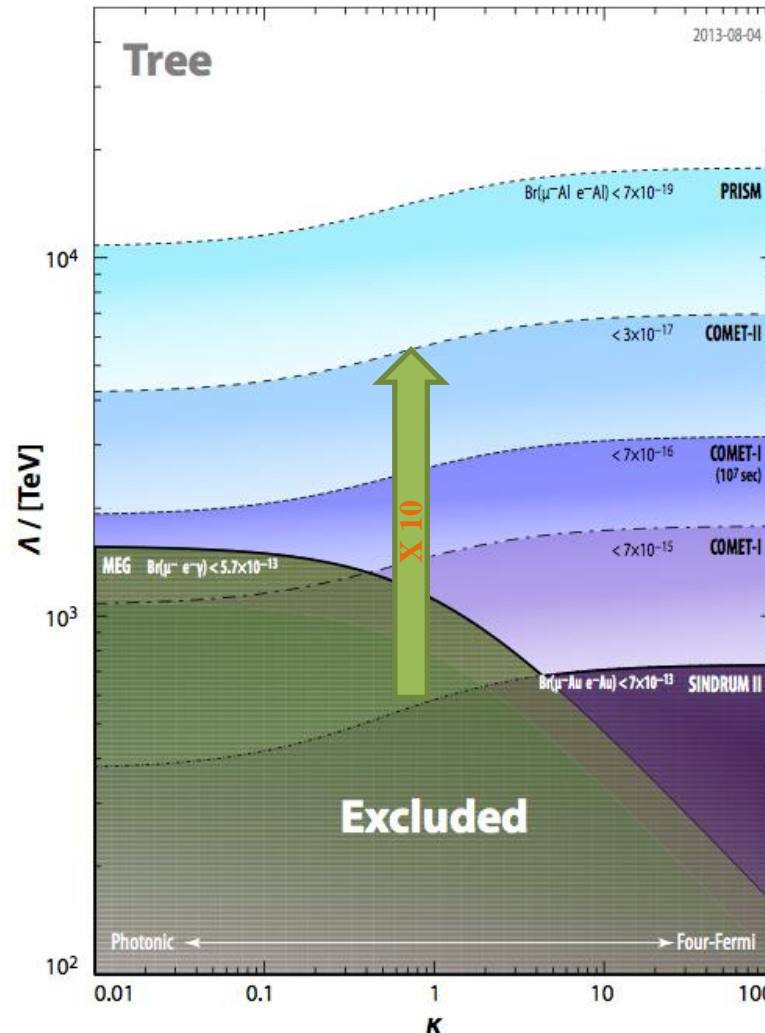

$\mu \rightarrow e\gamma$	$\mu - e$
No	Yes

# DC or Pulse?

- DC beam for coincidence experiments

- $\mu \rightarrow e\gamma, \mu \rightarrow e e e$

- Pulse beam for non-coincidence experiments

- $\mu$ -e conversion

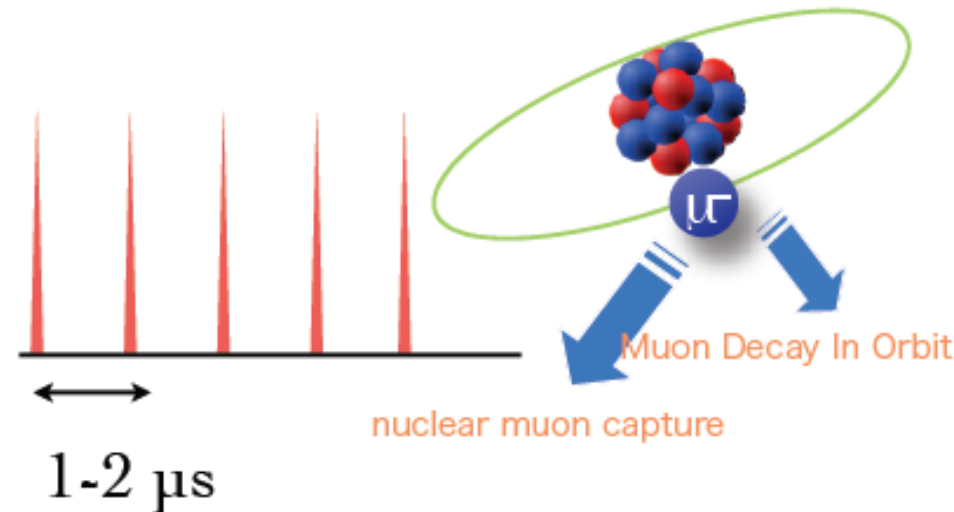
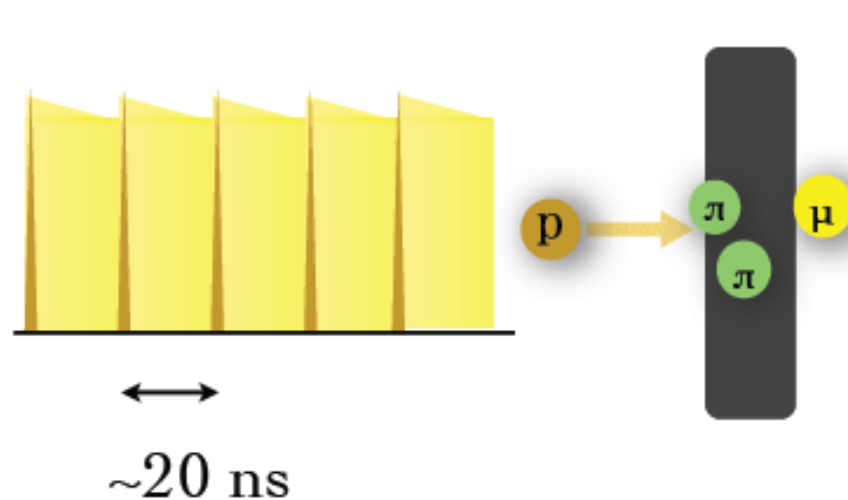

# MEG & MEG II

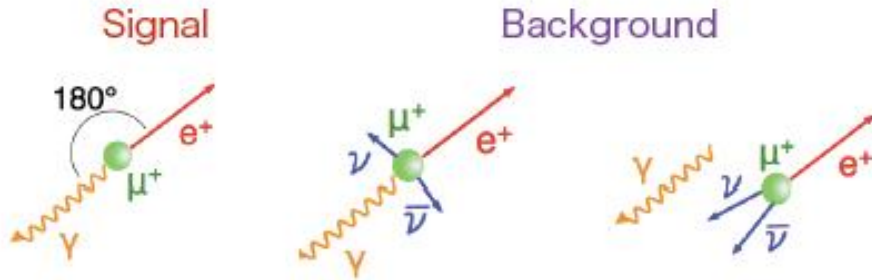

## MEG@PSI

- Search for  $\mu^+ \rightarrow e^+ \gamma$  using  $3 \times 10^7$  Hz muon beam
- Liquid Xe photon detector & COBRA positron spectrometer
- DAQ in 2008-2013
- Final upper limit result published:  $4.2 \times 10^{-13}$  @ 90% C.L.**
- European Physical Journal C, 76(8), 1-30
- Detector upgrade to achieve 10 times better sensitivity : MEG II
- See presentation by Marco Venturing (WG4) for more details

## MEG Muon Statistics

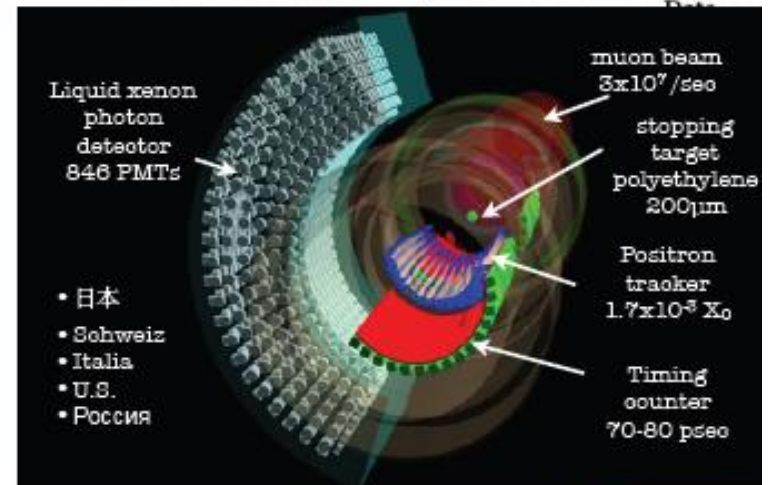
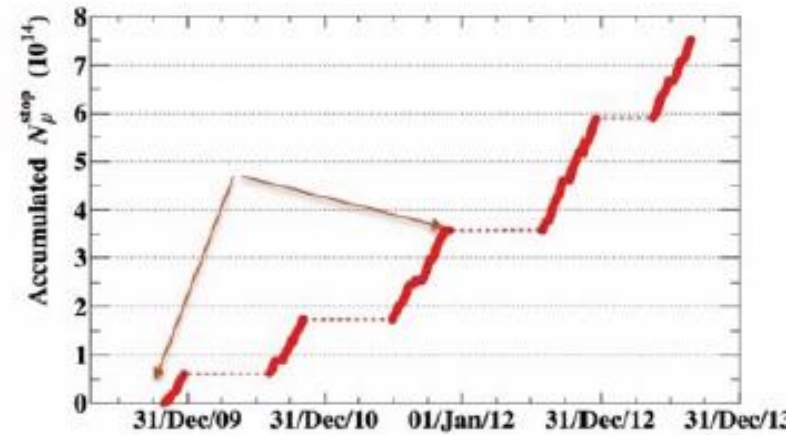

- 日本
- Schweiz
- Italia
- U.S.
- Россия

# MEG II

- Improve resolutions by about factor 2 everywhere

- $\mu$  beam rate of  $7 \times 10^7$  Hz to reach the sensitivity of  $4 \times 10^{-14}$

- Engineering run in 2016

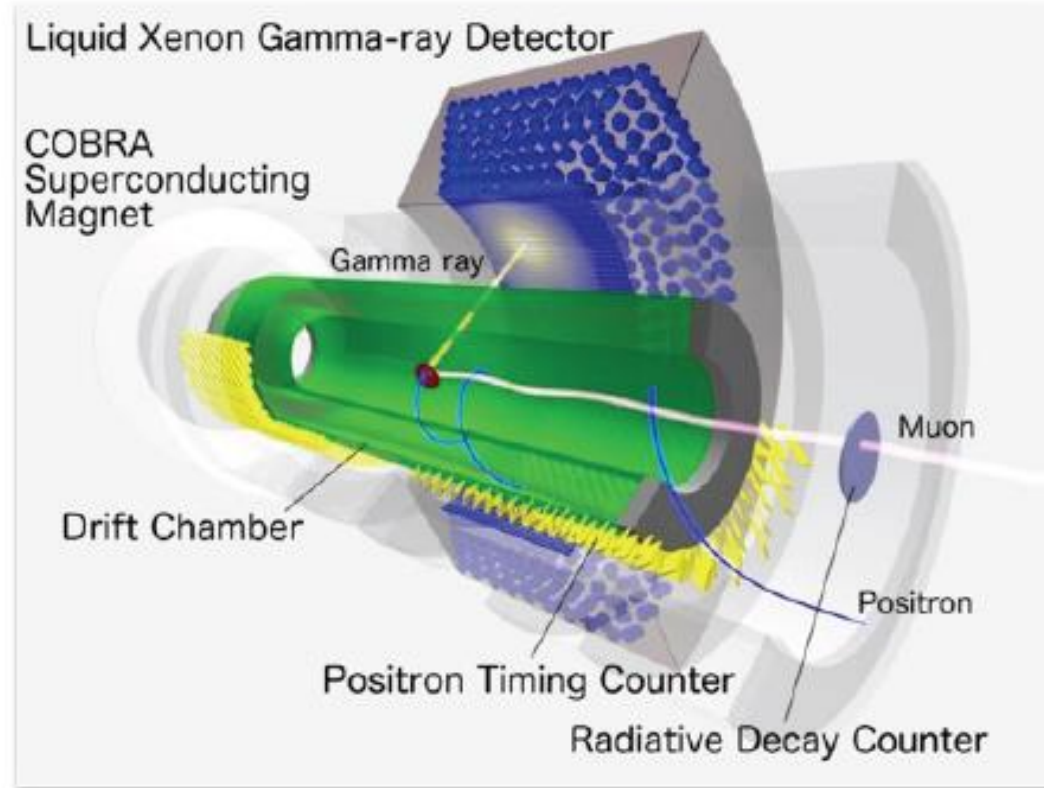

- See presentation by Angela Papa (WG4) for more details

# Physics background from $\mu \rightarrow e \nu \nu \gamma$

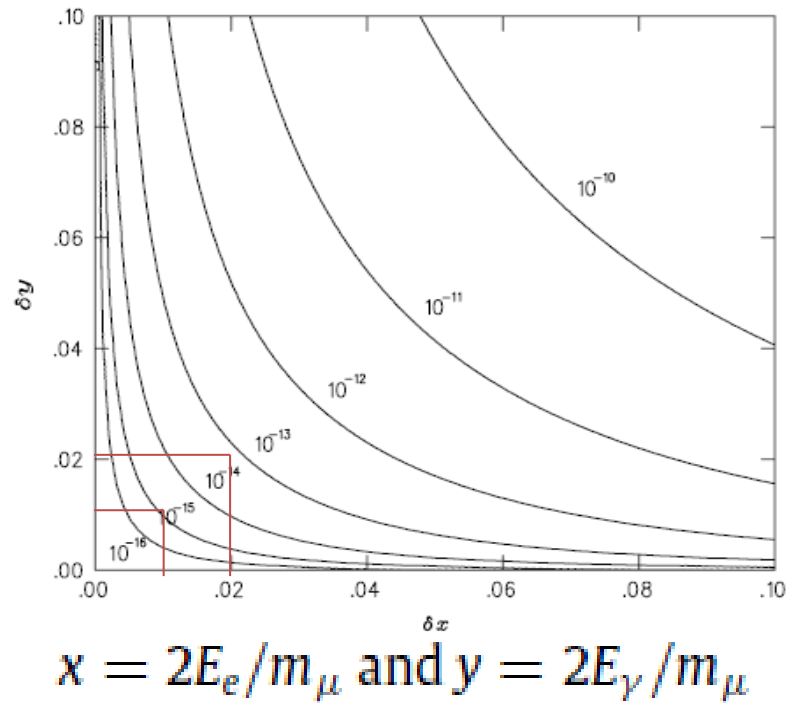

## All background levels in history

Historical progress of searches for  $\mu^+ \rightarrow e^+ \gamma$  since the era of meson factories with 90% confidence upper (C.L.) upper limits. The resolutions quoted are given as a full width at half maximum (FWHM).

Place	Year	$\Delta E_e$	$\Delta E_\gamma$	$\Delta t_{e\gamma}$ (ns)	$\Delta \theta_{e\gamma}$ (mrad)	Upper limit	Reference
TRIUMF	1977	10%	8.7%	6.7	-	$< 3.6 \times 10^{-9}$	[17]
SIN	1980	8.7%	9.3%	1.4	-	$< 1.0 \times 10^{-9}$	[18]
LANL	1982	8.8%	8%	1.9	37	$< 1.7 \times 10^{-10}$	[19]
LANL	1988	8%	8%	1.8	87	$< 4.9 \times 10^{-11}$	[20]
LANL	1999	1.2% <sup>a</sup>	4.5% <sup>a</sup>	1.6	15	$< 1.2 \times 10^{-11}$	[21]
PSI	2013	0.9%	5%	0.1	23	$< 5.7 \times 10^{-13}$	[2]
PSI MEGII		0.3%		0.035		$5 \times 10^{-14}$	

# The beam-line

- 590 MeV proton ring **cyclotron**
- the  $\pi$ **E5** beam line placed at  $175^\circ$  from the proton beam

$$3 \times 10^7 \mu^+ / s$$

$$p = 29 \text{ MeV}/c$$



# Mu3e: $\mu \rightarrow eee$ Search using DC Muon Beam

- Another channel sensitive to cLFV with DC muon beam

- $1.0 \times 10^{-12}$  (90% C.L.) by SINDRUM

- Goal :  $10^{-16}$  in 3 steps

- Phase I in 2018-2020  
Sensitivity:  $\sim 10^{-15}$

- Measure all electron tracks precisely

- most severe BG —

- $\mu^+ \rightarrow e^+ e^+ e^- \nu \nu$

- See presentation for more details by Angela Papa (WG4)

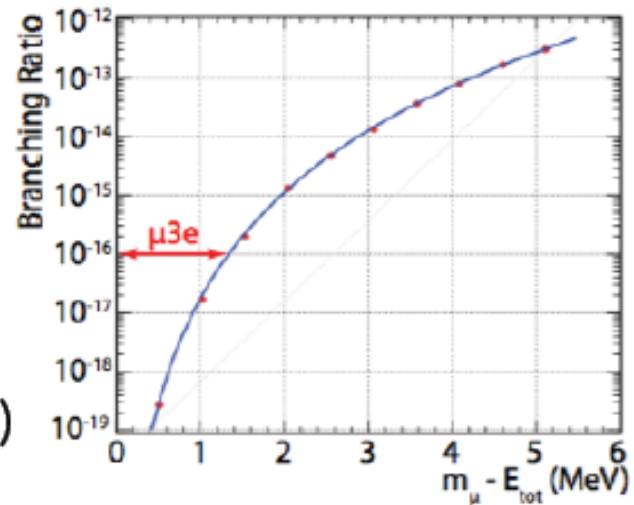
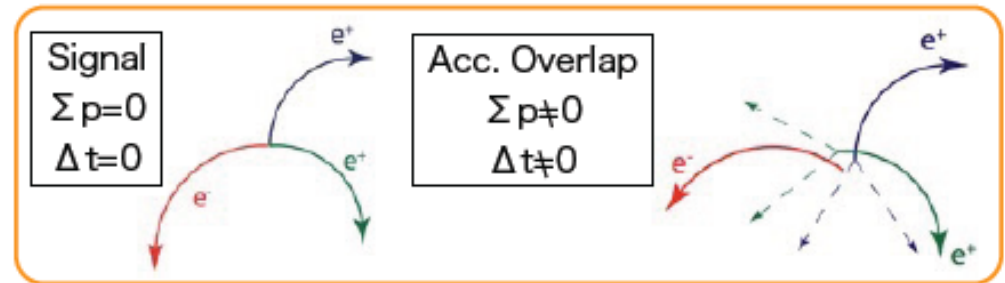
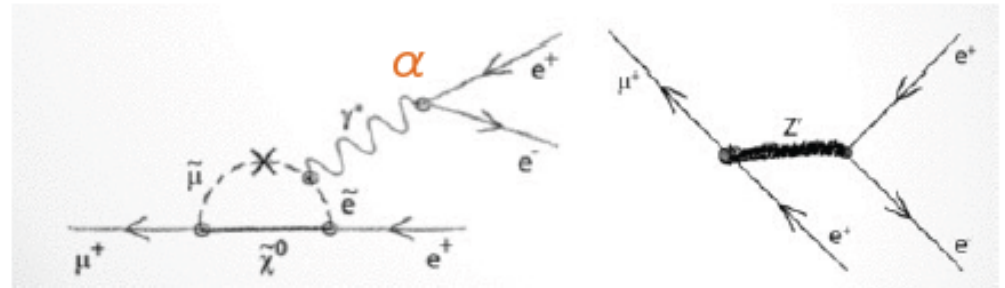

Suppress BG by more than 16 orders of magnitudes

# Mu3e detector concept

**Sensitivity phase I [2018-20]  $\sim 10^{-15}$**   
**(Final sensitivity phase II [202x]  $\sim 10^{-16}$**   
**needs  $10^9$  muons/s)**



# Muon to Electron Conversion

1s state in a muonic atom

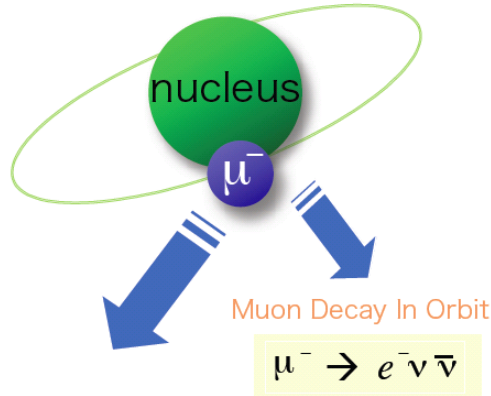

nuclear muon capture

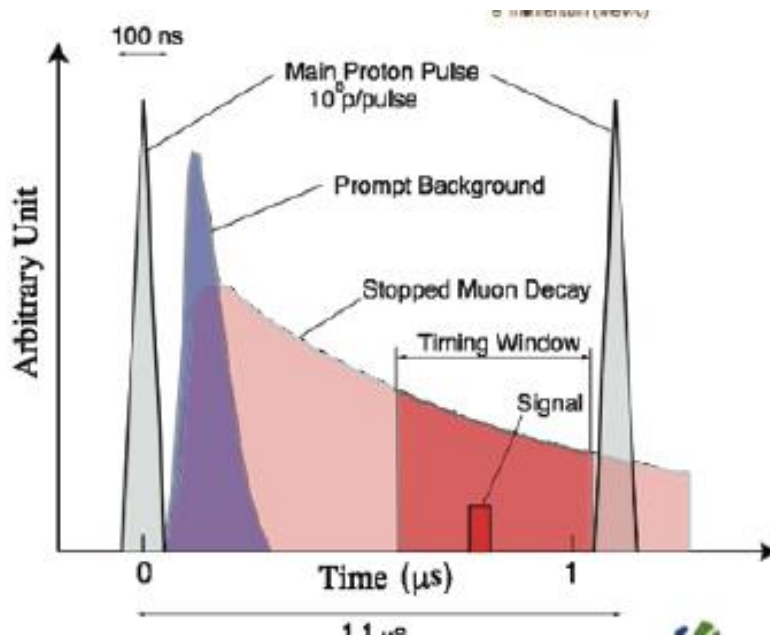
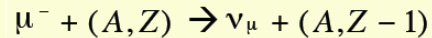

We are searching for:  
Neutrino-less muon nuclear capture

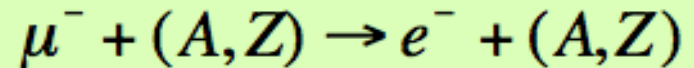

- **Event Signature:**

- a single mono-energetic electron of 105 MeV
- Free of accidental background.  
**No limit on beam intensity!**

- **Backgrounds:**

- **physics backgrounds**,  
ex. muon decay in orbit (DIO),  
radiative muon capture (RMC)
- **beam-related backgrounds**,  
ex. radiative pion capture, muon  
decay in flight, large angle  
scattering.  
**Can be suppressed by pulsed beam!**
- **cosmic rays, false tracking**

# Mu2E at Fermilab

- After Tevatron shutdown, use the antiproton accumulator ring and debuncher ring for beam pulsing.
- Proton beam power is 20 kW and >200 kW for pre and post Project-X, respectively.

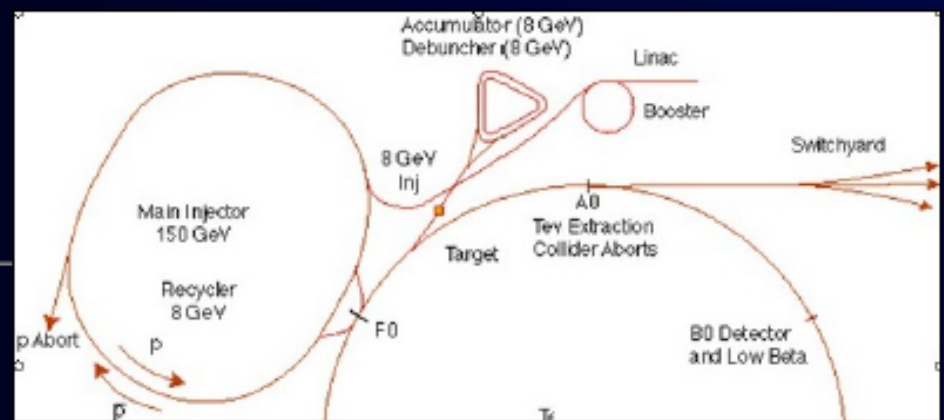

## Mu2E at Fermilab

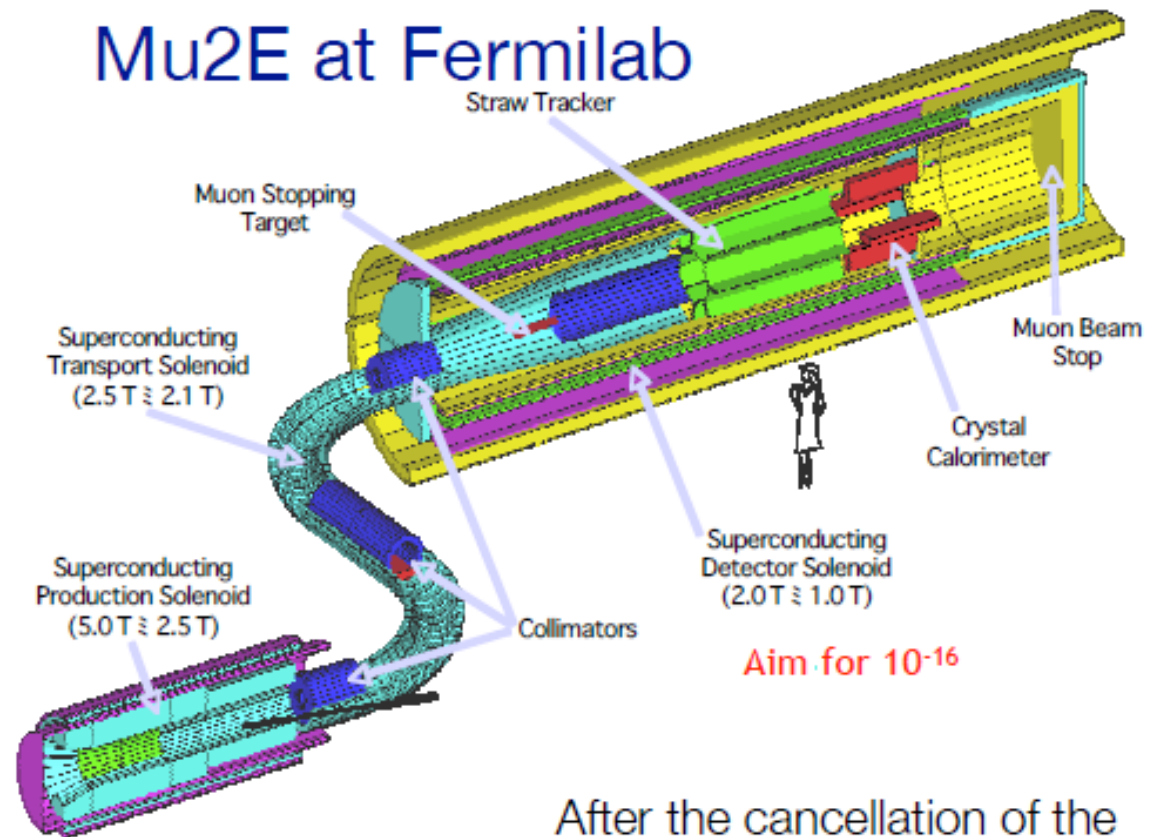

After the cancellation of the MECO experiment in 2005

# COMET (COherent Muon to Electron Transition) in Japan

$$B(\mu^- + Al \rightarrow e^- + Al) < 10^{-16}$$

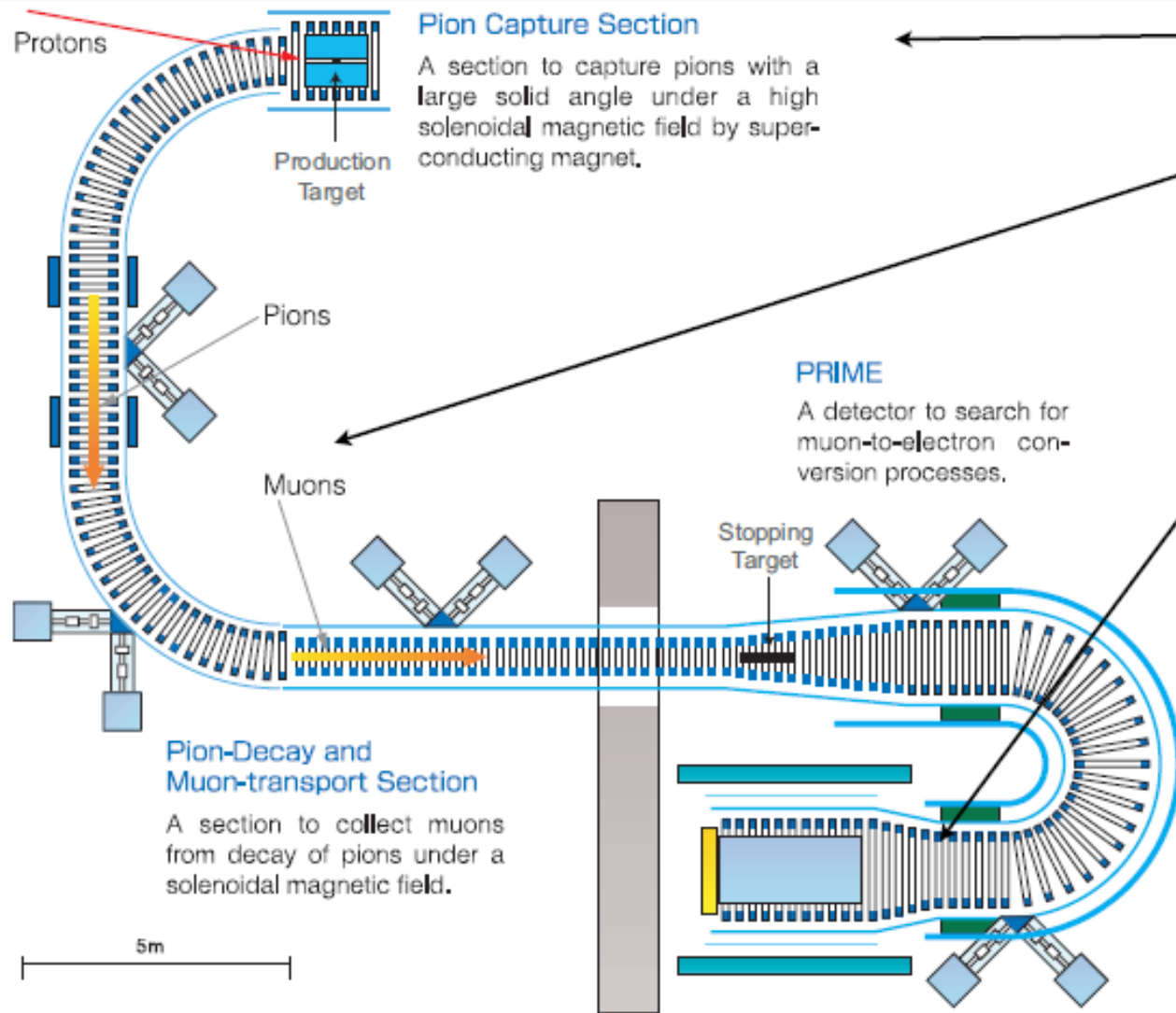

Proton Beam

The Muon Source

- Proton Target
- Pion Capture
- Muon Transport

The Detector

- Muon Stopping Target
- Electron Transport
- Electron Detection

proposed to  
J-PARC

# COMET Phase-I

The COMET Phase-I is designated to conduct the following tasks:

- 1 Background Study for COMET Phase-II:  
A direct measurement of potential **background** sources for the full COMET experiment by using the actual COMET beamline constructed at Phase-I.  
Using Phase-II detectors: straw tube tracker and energy calorimeter (ECal).
- 2 Search for mu-e conversion:  
A search for mu-e conversion at intermediate sensitivity which would be more than **100** times better than the SINDRUM-II limit.  
Using new detector dedicated for Phase-I: cylindrical detector.

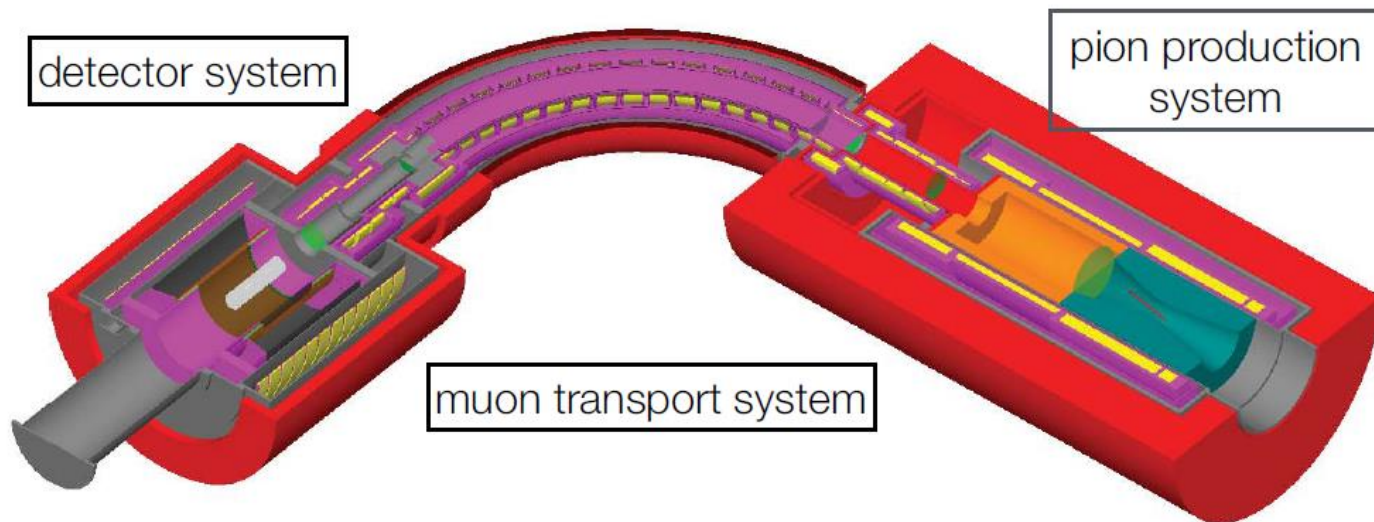

# PRISM Muon Beam

muon intensity:  $10^{11} \sim 10^{12}$  /sec  
 central momentum: 68 MeV/c  
 narrow momentum width by phase rotation  
 pion contamination :  $10^{-20}$  for 150m

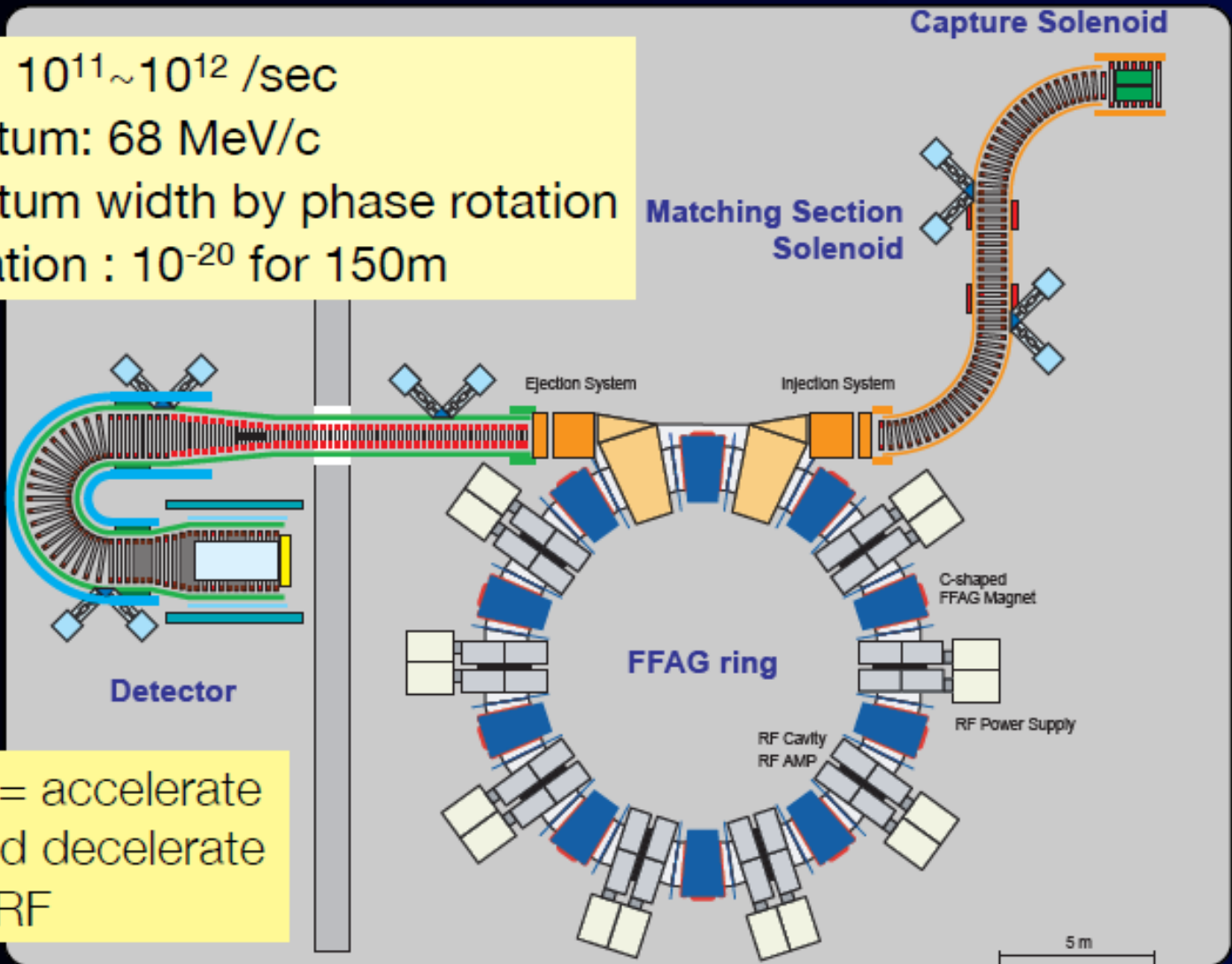

Phase rotation = accelerate  
 slow muons and decelerate  
 fast muons by RF

# Muon Summary

- Precision muon measurements  
(MuLan,FAST,TWIST,MuSan,MuLan,MUSE,MuSEAM,proton radius)
  - On going at Cyclotrons: CW, ~500 MeV, ~1MW, detector has potential
- g-2: 2<sup>nd</sup> generation on going
  - FermiLab: Bunches with 50ns/1us, 3GeV muon, 200kW (4MW)
  - JPARC: unclear...
- mu EDM
  - Bunches with 50ns/10us, 1-8GeV, 2MW (?)
- CLFV
  - mu-e gamma
    - On going at Cyclotrons: CW, ~500 MeV, ~1MW, detector close to rate limit
  - mu-e e e
    - On going at Cyclotrons: CW, ~500 MeV, ~1MW, new detector under designing
  - mu-e conv
    - ~2020: bunches with 100 ns / 1 us, 2~8 GeV, 50kW (0.5MW), detector OK
    - ~2030: bunches with 10 ns / 2 us, 2~8 GeV, 2MW (400MW), detector OK
  - mu e-e e
    - CW, 2~8 GeV, low power consumption, , detector OK

# Physics with Proton Sources

- Neutrino Physics
  - Neutrino Oscillation
  - Sterile Neutrino
  - Heavy Neutrino
- Muon Physics
  - CLFV
  - $g-2$
  - $\mu$ EDM
  - Precision Measurements
- Kaon/Pion Physics
  - $K \rightarrow \pi, \nu, \nu$
- Neutron Physics
  - nEDM

# Summary: Rare Kaon Decays

Exceptional sensitivity to new Flavor Physics

CERN NA62 ( $K^+ \rightarrow \pi^+ \nu \bar{\nu}$ ) and JPARC KOTO ( $K_L^0 \rightarrow \pi^0 \nu \bar{\nu}$ ) poised to begin soon.

\* Fermilab: great potential for advancing the intensity frontier

"Ultimate" high precision experiments possible

\* Significant work can be done with existing facilities:

**MI+Tevatron Strecher:  $K^+ \rightarrow \pi^+ \nu \bar{\nu}$**

\* Project X ICD-2 would provide extraordinary

possibilities for measuring  **$K_L^0 \rightarrow \pi^0 \nu \bar{\nu}$**

# Experiments

Prospects for 10-1000 x improvements.

## Lepton Flavor Violation

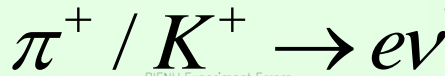
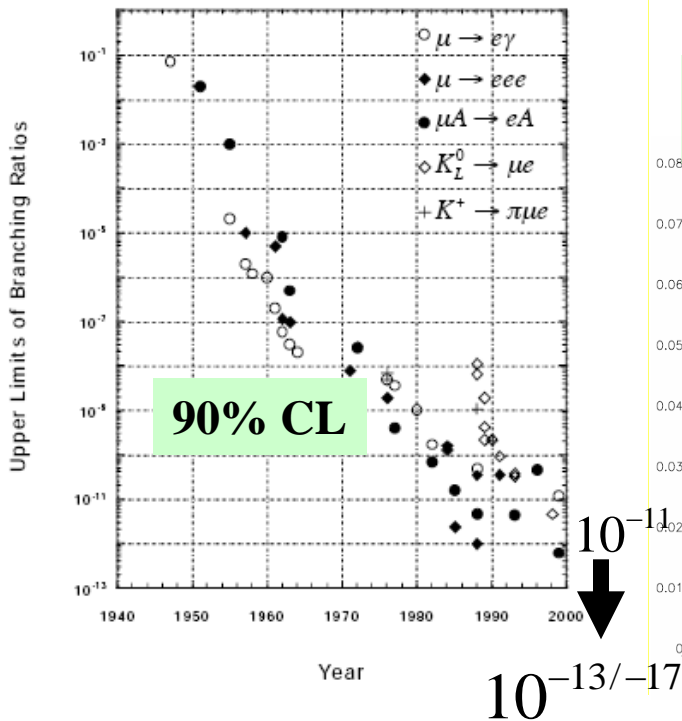

Precision

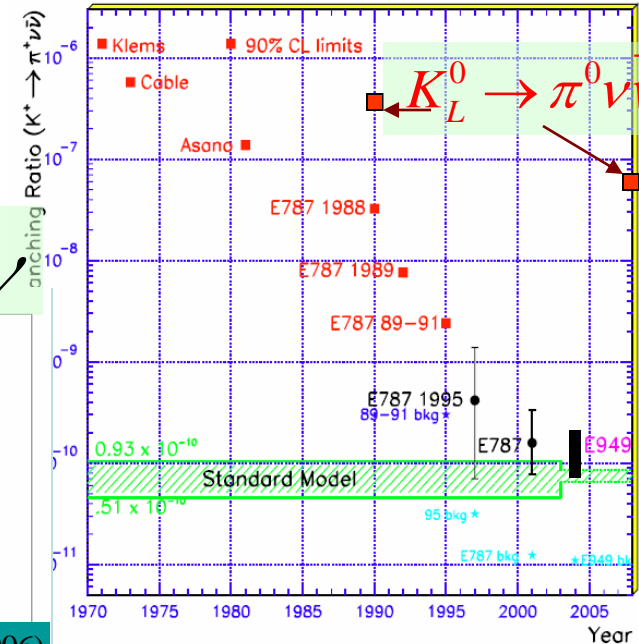
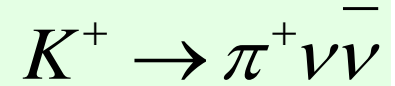
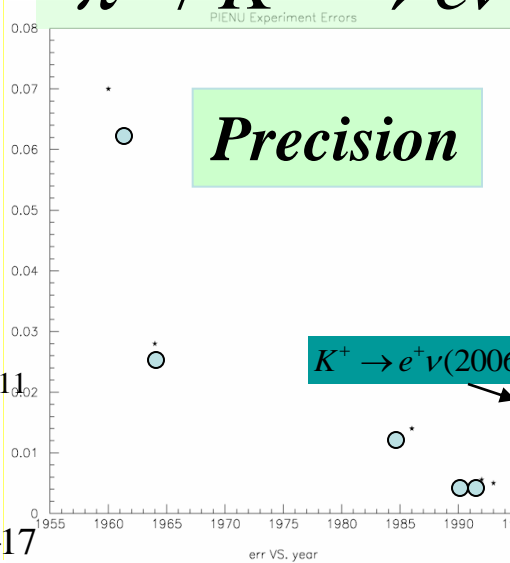

7

100

1000

# $K \rightarrow \pi \nu \bar{\nu}$ Experiments

$$K^+ \rightarrow \pi^+ \nu \bar{\nu}$$

- BNL E787/949:  $B(K^+ \rightarrow \pi^+ \nu \bar{\nu}) = 1.73_{-1.05}^{+1.15} \times 10^{-10}$
- CERN NA62; New Technique
- New proposal: Fermilab P996
- Fermilab Project X?

$$K_L^0 \rightarrow \pi^0 \nu \bar{\nu}$$

- KEK E391a:  $B(K_L^0 \rightarrow \pi^0 \nu \bar{\nu}) < 6.7 \times 10^{-8}$
- JPARC KOTO
- Fermilab Project X?

# Kaon production (K.Gudima, MARS15-LAQGSM)

Optimal production rate at  $T_p \geq 4$  GeV is 8-10 $\times$  rate at  $T_p = 2$  GeV

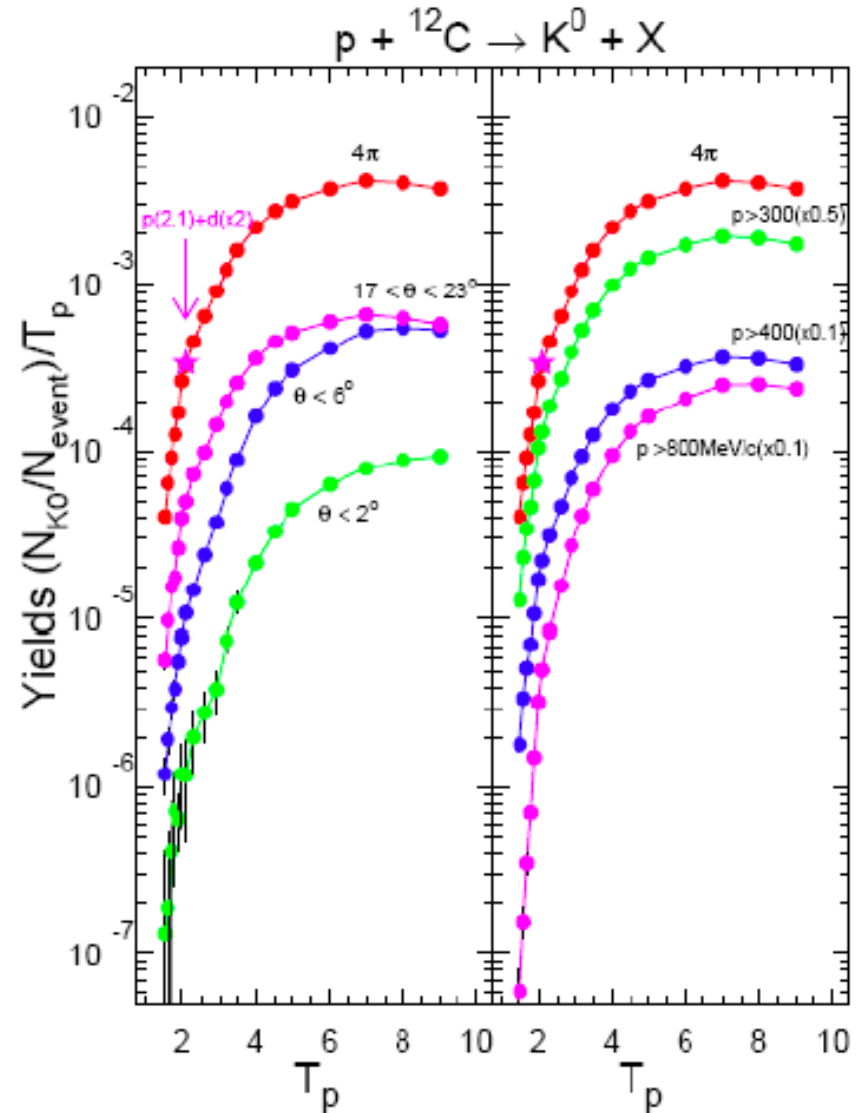
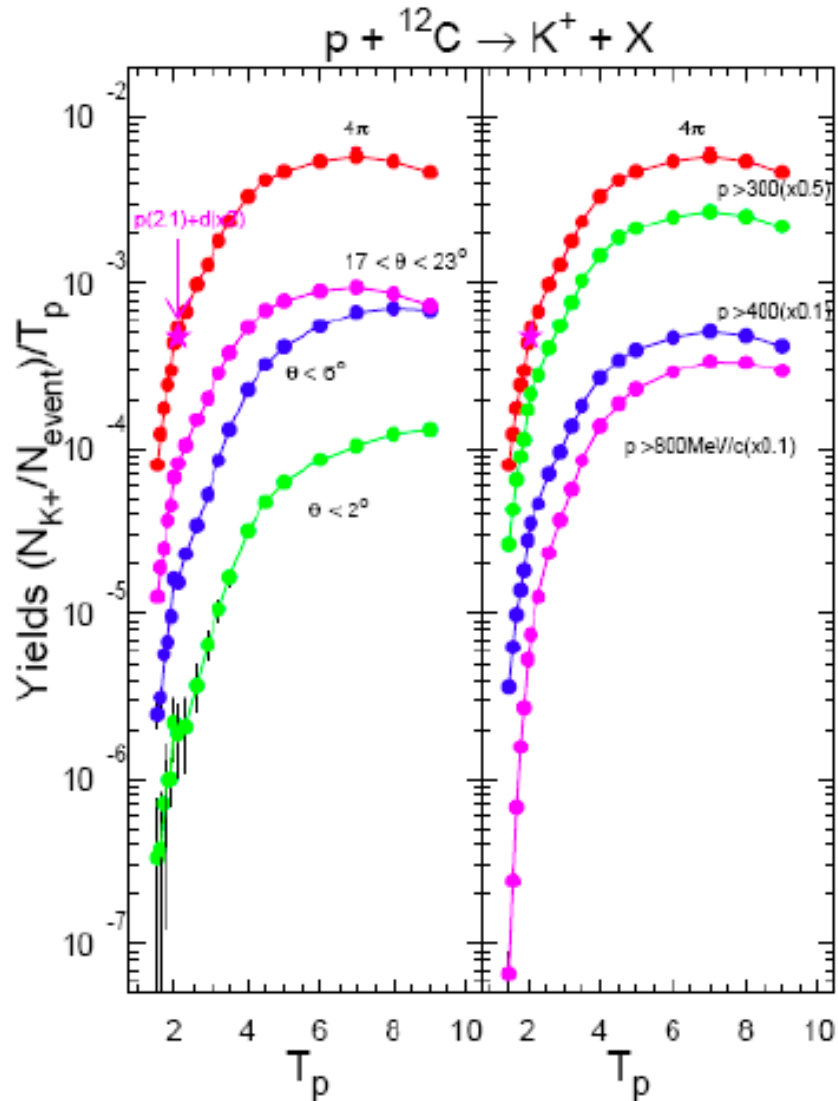

# $K \rightarrow \pi \nu \bar{\nu}$ at Project X

	$K^+ \rightarrow \pi^+ \nu \bar{\nu}$	$K_L^0 \rightarrow \pi^0 \nu \bar{\nu}$
Beam time structure	DC	pulsed (25 MHz)
Proton beam energy	2.6-6 GeV	2.6-6 GeV
Beam pulse width	NA	< 50 ps
Beam pulse interval	NA	~ 40 ns
Extinction	NA	$10^{-3}$
Beam power	2 MW	2 MW

Both experiments prefer ICD-2.

Maximum power would allow reduction of phase space of kaon beams for higher beam purity, detection efficiency.

# $\pi^+ \rightarrow e^+ \nu_e$ and Massive Neutrinos

•  $\pi^+$  branching ratio R in SM

$$R_{\text{SM}} = \frac{\Gamma((\pi \rightarrow e \nu) + (\pi \rightarrow e \nu \gamma))}{\Gamma((\pi \rightarrow \mu \nu) + (\pi \rightarrow \mu \nu \gamma))}$$

$$= (1.2352 \pm 0.0002) \times 10^{-4}$$

$\pi^+ \rightarrow e^+ \nu_e$  is **helicity suppressed**.

V.Cirigliano, I.Rosell, PRL 99 231801 (2007)

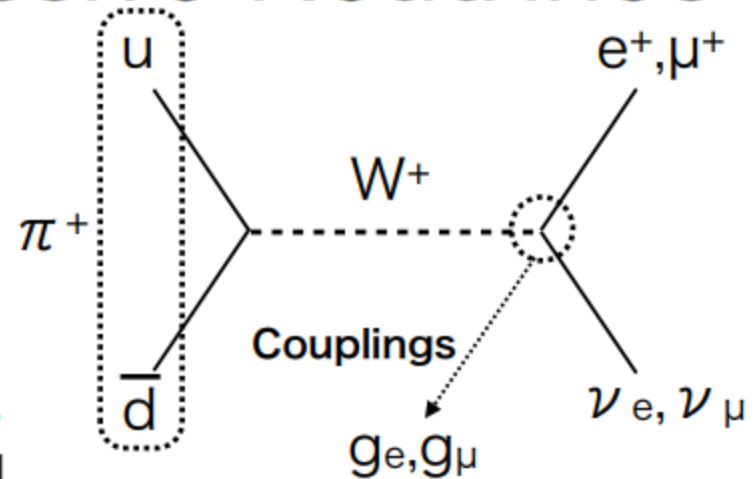

If massive neutrinos exist...

→ **Affects pion branching ratio**

- A change in the phase space.
- Apparent violation of equality of the weak interaction couplings.
- Relaxation of helicity suppression.

→ **Additional  $\pi^+ \rightarrow e^+ \nu_\chi$  would be detected.**

$m_\nu: 60 \sim 130 \text{ MeV}/c^2$

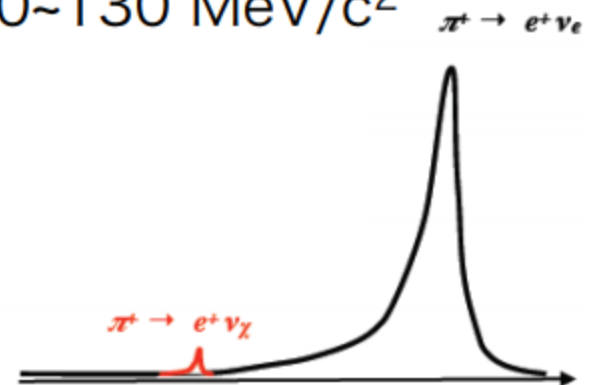

# Measurement Strategy

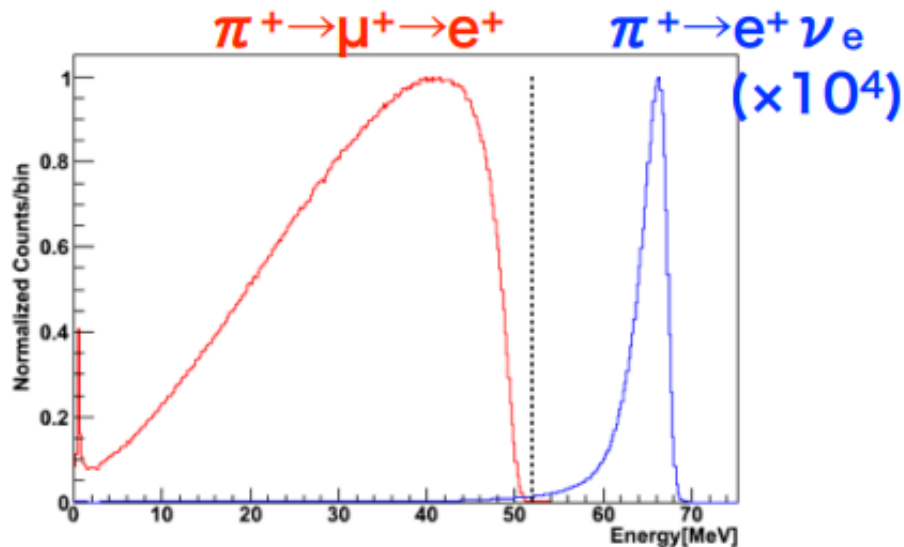
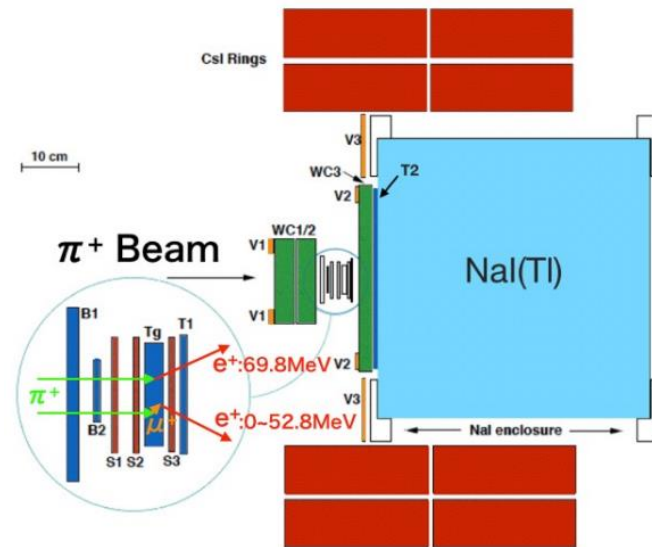
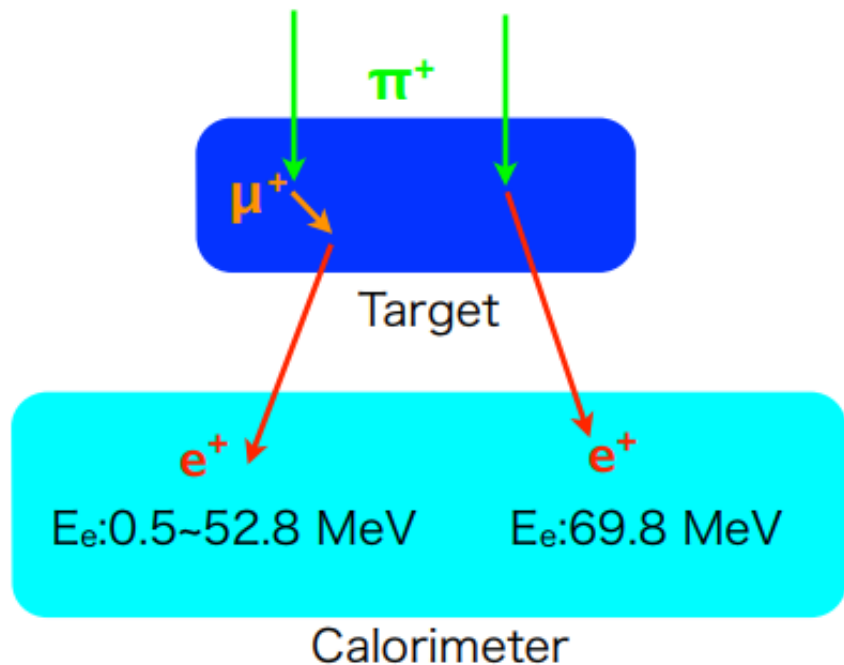

Decay positron energy (MC)

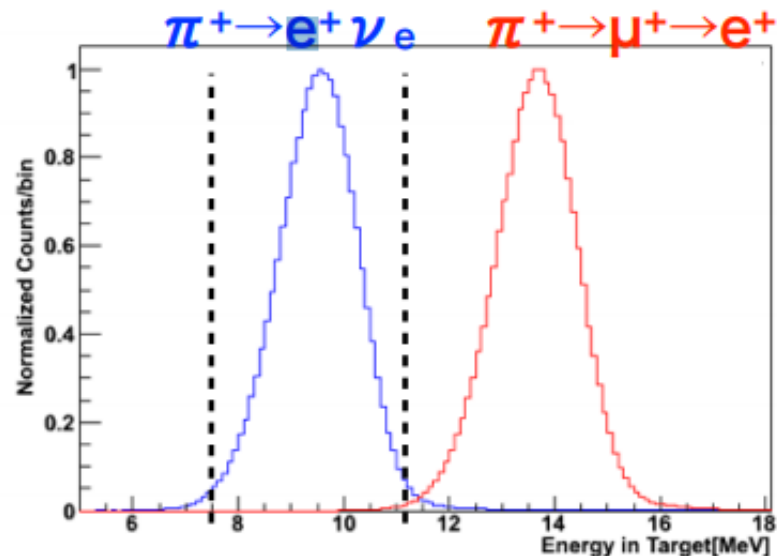

Energy in the target (MC)

# $\pi^+ \rightarrow e^+ \nu_e$ Decay

- $\pi^+$  branching ratio R in SM

$$R_{\text{SM}} = \frac{\Gamma((\pi \rightarrow e \nu) + (\pi \rightarrow e \nu \gamma))}{\Gamma((\pi \rightarrow \mu \nu) + (\pi \rightarrow \mu \nu \gamma))}$$

$$= \frac{g_e^2 m_e^2 (m_\pi^2 - m_e^2)^2}{g_\mu^2 m_\mu^2 (m_\pi^2 - m_\mu^2)^2} (1 + \delta)(1 + \varepsilon)$$

Radiative Correction

$$= (1.2352 \pm 0.0001) \times 10^{-4} \quad \mathbf{(0.01\%)}$$

V.Cirigliano, I.Rosell, PRL 99 231801 (2007)

- $g_e = g_\mu$ : **lepton universality.**
- $\pi^+ \rightarrow e^+ \nu_e$  is disfavored (V-A).

➔ **Helicity suppression.**

- Experimental result

$$R_{\text{EXP}} = (1.2344 \pm 0.0023(\text{stat}) \pm 0.0019(\text{syst})) \times 10^{-4}$$

(From  $10^6$   $\pi \rightarrow e \nu$  events)

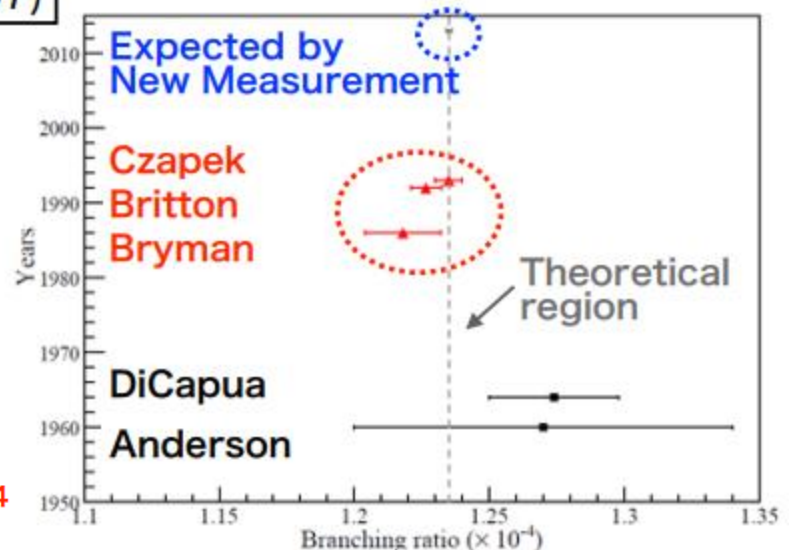
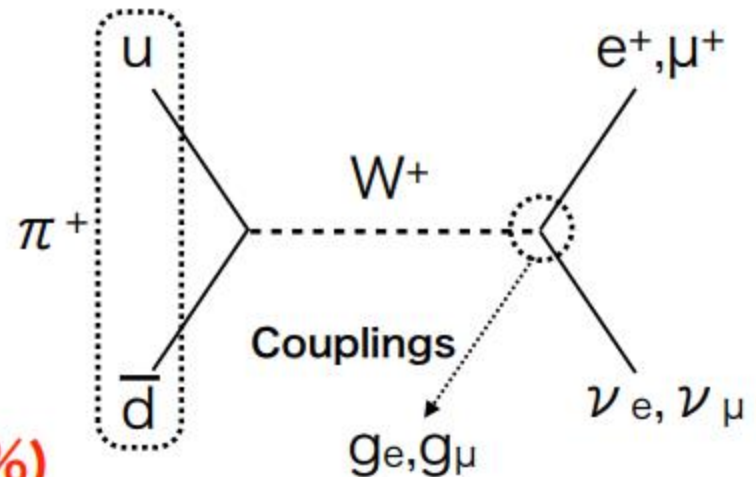

History of R measurement.

# Sensitivity to Massive Neutrino

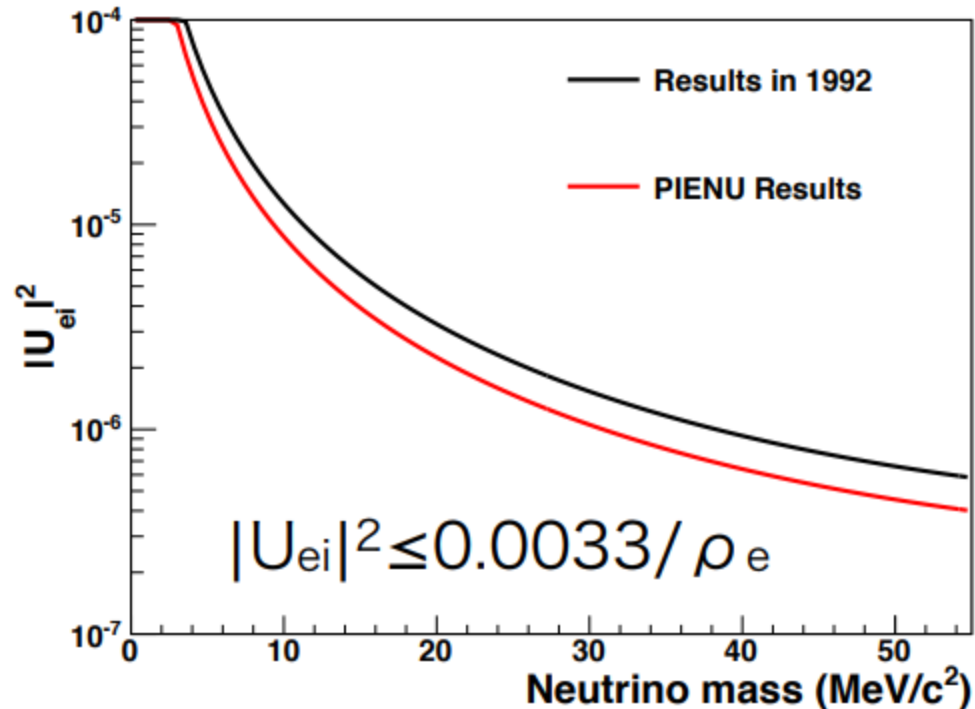

- Factor of **1.5** improvement over previous result in  $\leq 55$  MeV/c<sup>2</sup>.
- Branching ratio and neutrino results submitted  $\Rightarrow$  coming soon!!
- Full statistics: **>×10**
  - $\rightarrow$  Sensitivity will be improved by a factor of **>3**.

# Sensitivity to Majorons

- Nambu-Goldstone bosons (Majorons) occur in gauge models with spontaneously broken global B-L symmetry.
- In the presence of Majorons M, the expected branching ratio is slightly higher.

$$\frac{\Gamma(\pi \rightarrow e L^0) / \Gamma(\pi \rightarrow \mu L^0)}{\Gamma(\pi \rightarrow e \nu) / \Gamma(\pi \rightarrow \mu \nu)} = 1 + 157.5 g_M^2 \overset{\text{Majoron-neutrino coupling}}{\nearrow}$$

G.B. Gelmini and M. Roncadelli.,  
Phys.Lett. 99B 411 (1981)

- $L^0$ : final states of  $\nu$ ,  $\nu M$ , and  $\nu \chi$  (very light Higgs particle).
- Previous result:  $g_M^2 < 3 \times 10^{-5}$  This result:  $g_M^2 < 2.1 \times 10^{-5}$

(90% C.L.)

# Kaon/Pion Summary

- Rare Kaon decays
  - Proposed at FNAL & J-PARC: **pulsed, 2GeV, 2MW**
- Precision pion measurements
  - On going at Cyclotrons: CW, **~500 MeV, ~1MW**
  - Detector has potential to handle higher rate

# Physics with Proton Sources

- Neutrino Physics
  - Neutrino Oscillation
  - Sterile Neutrino
  - Heavy Neutrino
- Muon Physics
  - CLFV
  - $g-2$
  - $\mu$ EDM
  - Precision Measurements
- Kaon/Pion Physics
  - $K \rightarrow \pi, \nu, \nu$
- Neutron Physics
  - nEDM

# Accelerator-Driven Spallation Sources

- Produce neutrons for use in condensed matter and basic physics research
- Want neutron wavelengths about the dimensions of interest, or neutron energies that can probe the dynamics of interest
- The pulsed nature of the neutron beams allows for energy determination by time of flight (which you can't do with a reactor source)
  - Exception noted for the SINQ source which uses the PSI cyclotron

## What's Important?

- Accelerator parameters
  - power on target – 7 kW (IPNS) to 1 MW (SNS)
  - proton energy – 450 MeV (IPNS) to 3 GeV (JSNS)
  - pulse rate 10 Hz (ISIS TS2) to 25 Hz (JSNS) to 60 Hz (SNS)
  - pulse length – sub- $\mu$ s (short pulse), 1-2 ms (long pulse), CW (SINQ)
- Neutron economy in target (production, absorption)
- Moderator efficiency, coupling to target
- Neutron energy spectrum and emission time distribution

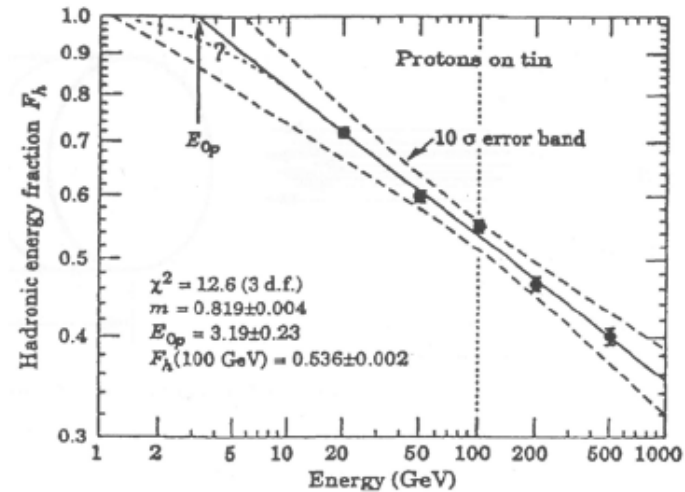

## Types of Accelerator-Driven Spallation Sources

- Linac + synchrotron (IPNS, ISIS, JPARC)
- Linac + accumulator (compression) ring (SNS, LANSCE, original ESS)
- Cyclotron (SINQ)

# Neutron EDM Efforts

## nEDM @ PSI

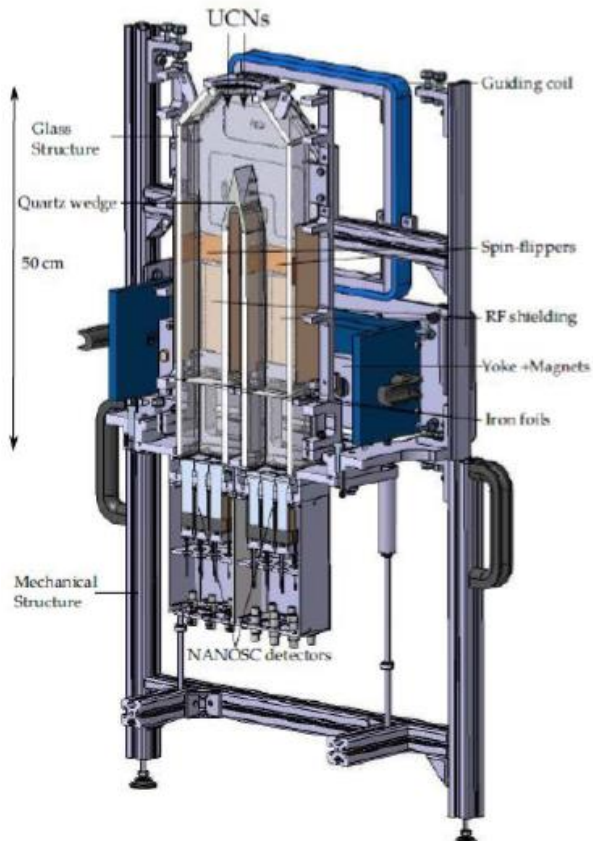

- Current sensitivity  $\sim 2 \times 10^{-26}$  e·cm
- nEDM@PSI should reach sensitivity  $10^{-26}$  e·cm in 2016
- Next generation n2EDM (start 2018-19)
  - Mu-metal Shield
  - Double chamber setup (two E direction)
  - Magnetometers (improved  $^{199}\text{Hg}$ , He-3)
- Goal:  $3 \times 10^{-27}$  e·cm early 2020s
- Also: [SNS EDM](#) effort in critical component demonstration phase now, integration  $\sim 2018$ , data early 2020s
- Many other nEDM efforts worldwide

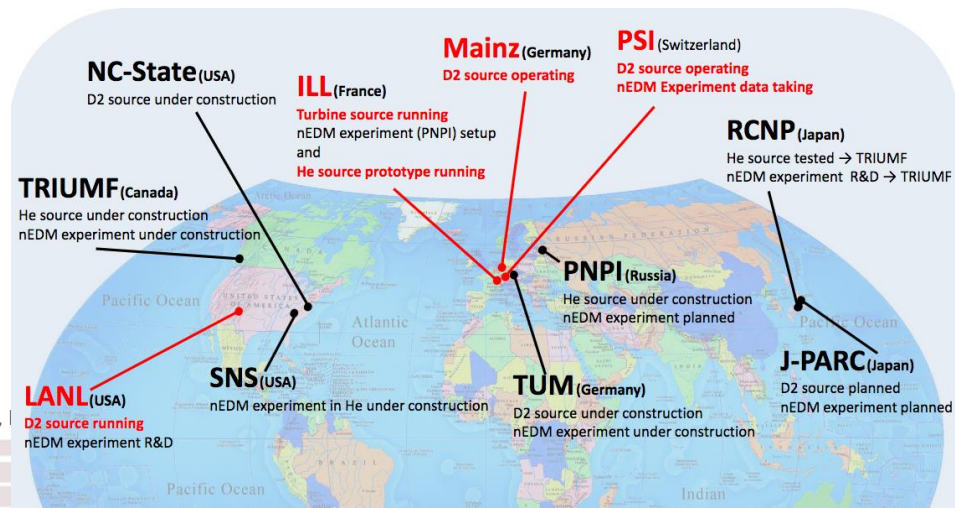

# EDMs - Summary and outlook

- EDM limits for various systems (some limits assume a single source)

Type	System	EDM limit (e·cm)
Paramagnetic molecule	YbF	$d_e = (-2.4 \pm 5.9) \times 10^{-28}$
	ThO	$d_e = (-2.1 \pm 4.5) \times 10^{-29}$
Diamagnetic atom	$^{199}\text{Hg}$	$d_{\text{Hg}} = (2.2 \pm 3.1) \times 10^{-30}$
	$^{225}\text{Ra}$	$d_{\text{Ra}225} = (-0.5 \pm 2.51) \times 10^{-22}$
Nucleon	n	$d_n = (0.21 \pm 1.82) \times 10^{-26}$

- Full interpretation to understand underlying CPV interaction requires theory
- While experiments have set impressive limits, order of magnitude improvements expected over the next decade:
  - Several nEDM experiments with up to 2 orders of magnitude improvement
  - Octupole enhanced systems  $^{225}\text{Ra}$  and  $^{221}\text{Rn}/^{223}\text{Rn}$
  - Light charged particle EDMs in storage rings
  - ...

# Neutron Summary

- nEDM
  - On going at LINAC/Cyclotron with SNS type targets: CW, <1GeV, ~MW

# Summary

- Neutrino Oscillation/Sterile neutrino:
  - Bunched beam, high energy: synchrotron?
- Heavy neutrino/Dark photon
  - up to 400 GeV proton, LINAC OK
- Precision muon measurements (MuLan,FAST,TWIST,MuSan,MuLan,MUSE,MuSEAM,proton radius)
  - On going at Cyclotrons, LINAC OK but physics potential limited
- g-2: 2<sup>nd</sup> generation on going, 5 sigma expected
  - mu EDM
- CLFV
  - mu-e gamma/ mu-e e e
    - On going at Cyclotrons, LINAC OK, physics potential depends on detector design
  - mu-e conv
    - 100 ns/1 us bunch structure, ~GeV, MW in future, Synchrotron?
- Rare Kaon decays
  - Proposed at FNAL & J-PARC: **pulsed, 2GeV, 2MW**
- Precision pion measurements
  - On going at Cyclotrons: **CW, ~500 MeV, ~1MW**
  - Detector has potential to handle higher rate
- nEDM
  - On going at LINAC/Cyclotron with SNS type targets: **CW, <1GeV, ~MW**